

ANGEL TYP98

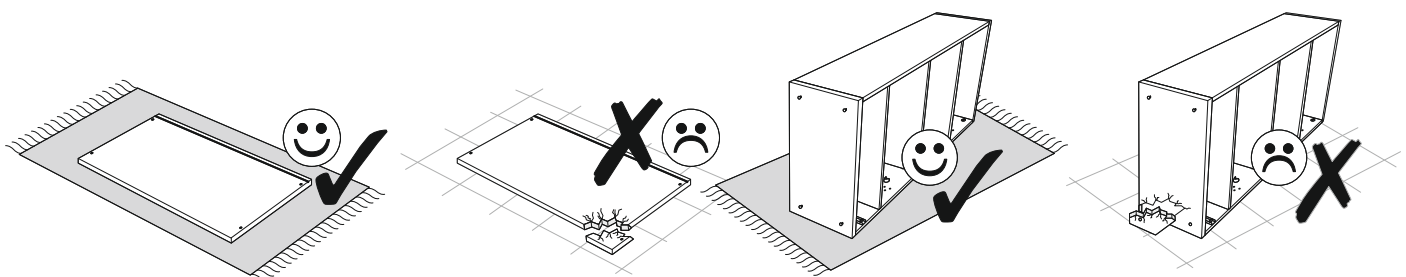

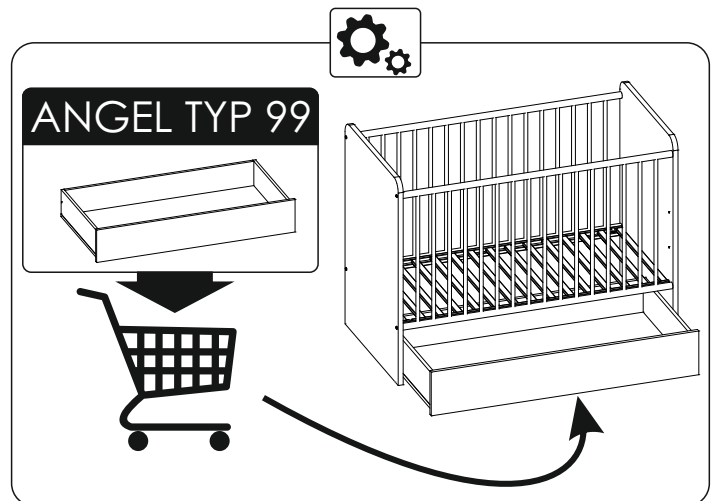

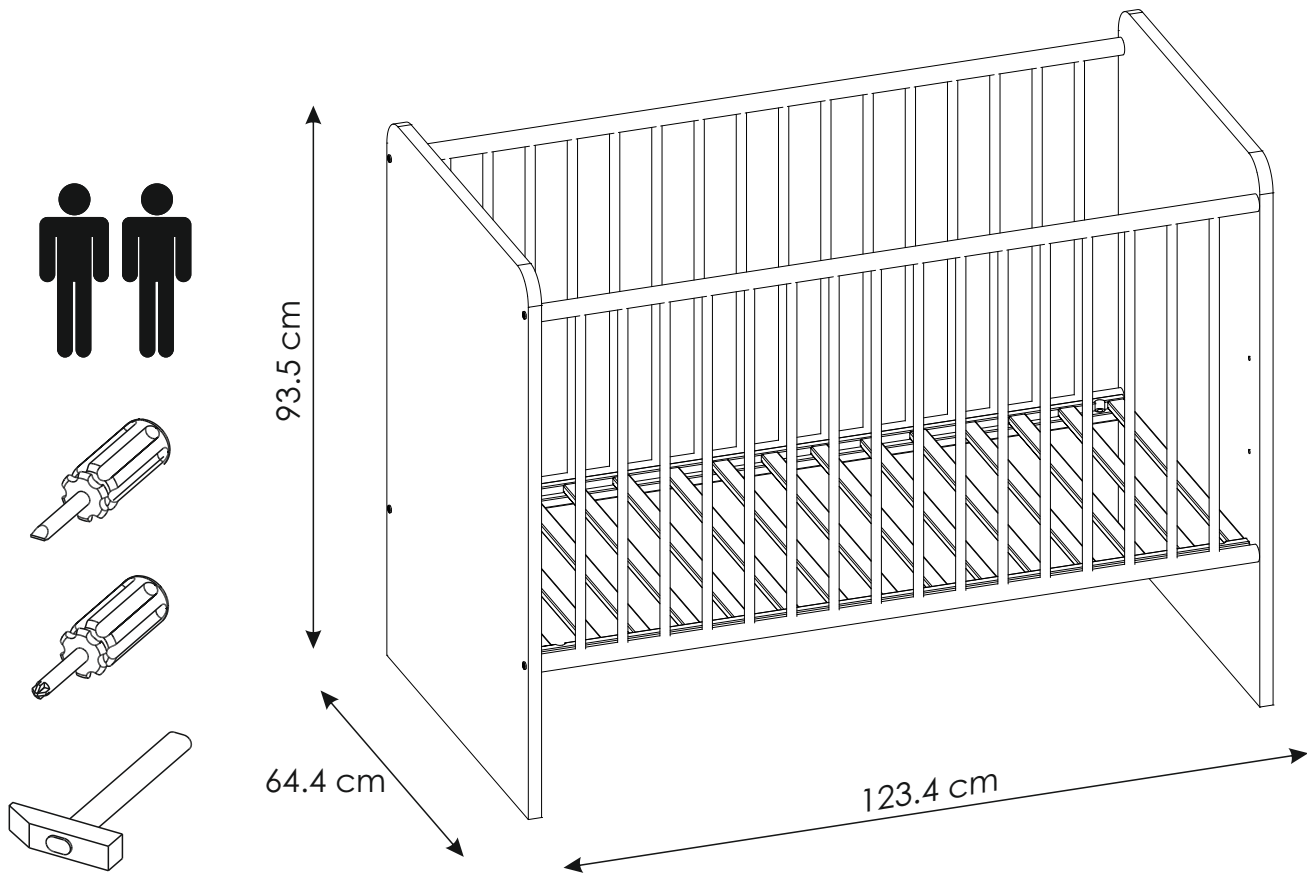
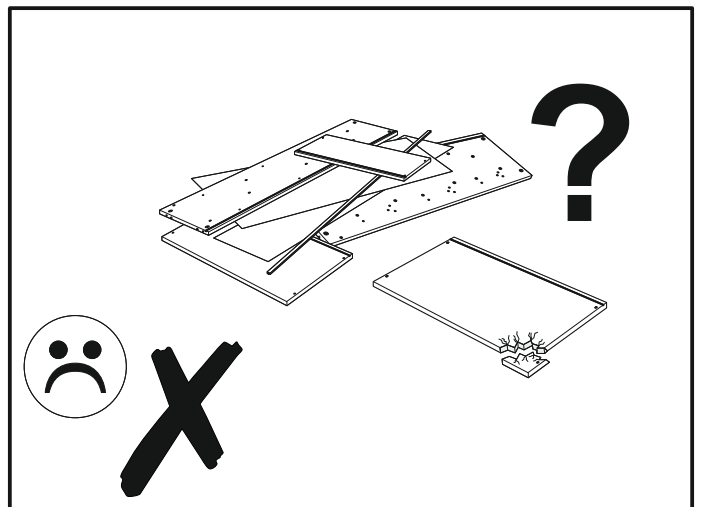
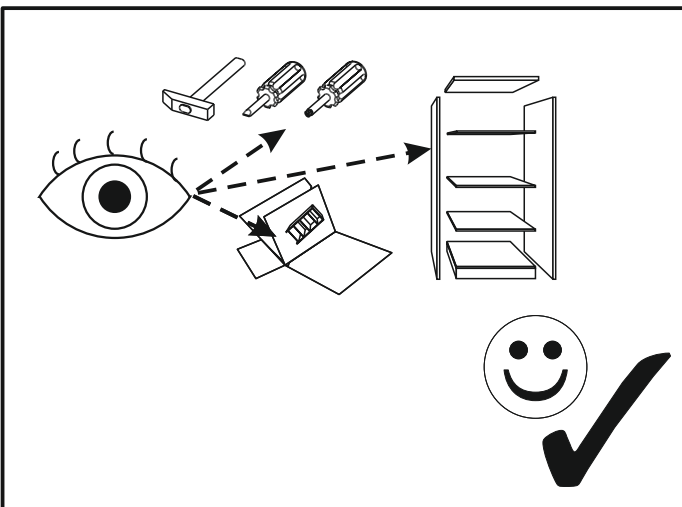
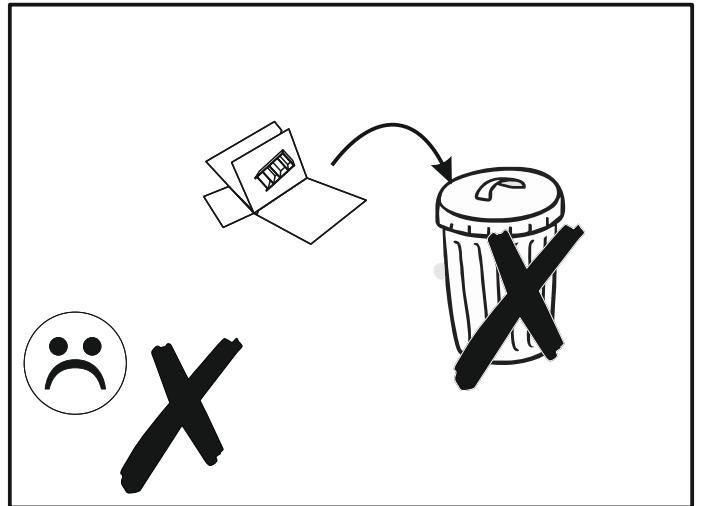
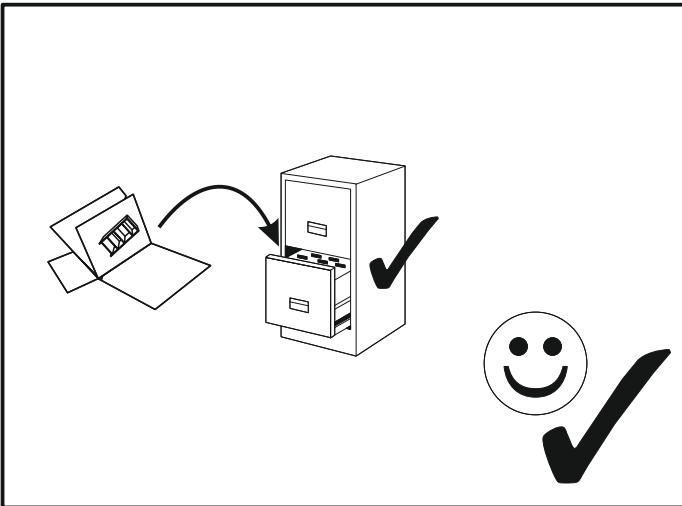
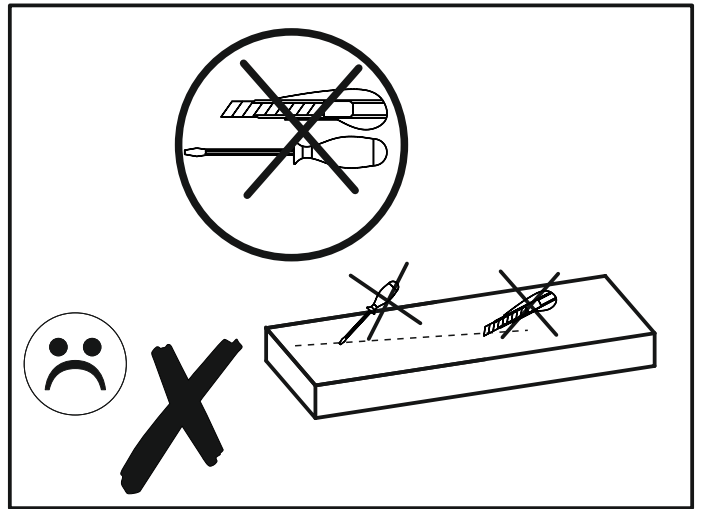
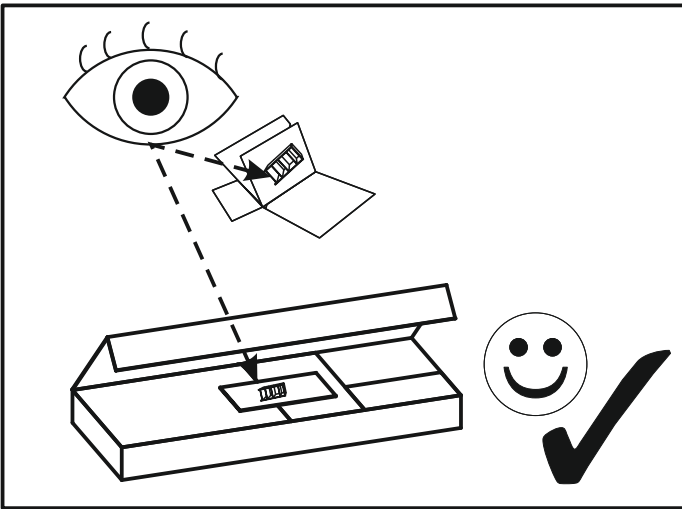

OSTRZEŻENIE

W pobliżu łóżka nie używać otwartego ognia i innych źródeł silnego ciepła takich jak grzejniki elektryczne lub gazowe i inne.

Nie używać łóżka, jeżeli jakaś część jest uszkodzona lub jest jej brak.

Nie pozostawiać w łóżku czegokolwiek ani nie ustawiać łóżka w pobliżu innego sprzętu, który mógłby stanowić podparcie dla stopy lub spowodować niebezpieczeństwo uduszenia lub powieszenia dziecka, np. przewody, sznurki, zasłony i inne.

Nie używać w łóżku więcej niż jednego materaca.

Zaleca się aby wszystkie okucia podczas ich montażu były dobrze dokręcone oraz regularnie sprawdzane i w razie konieczności dokręcane.

Aby zapobiec obrażeniom dziecka w skutek upadku łóżko nie powinno być dłużej używane, jeśli dziecko potrafi się wspiąć i wyjść z łóżka.

Najniższe położenie dna łóżka jest najbezpieczniejsze. Gdy dziecko zaczyna samodzielnie siadać zaleca się używać tylko tego poziomu.

Grubość materaca powinna być taka, aby wewnętrzna wysokość (mierzona od górnej płaszczyzny materaca do górnej krawędzi ramy łóżka) wynosiła co najmniej 500 mm w najniższym położeniu dna i co najmniej 200 mm w najwyższym położeniu dna łóżka.

ANGEL TYP98

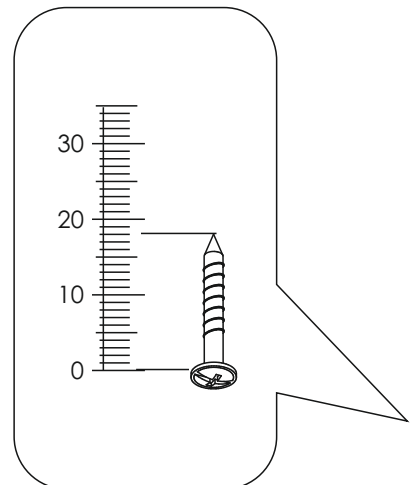
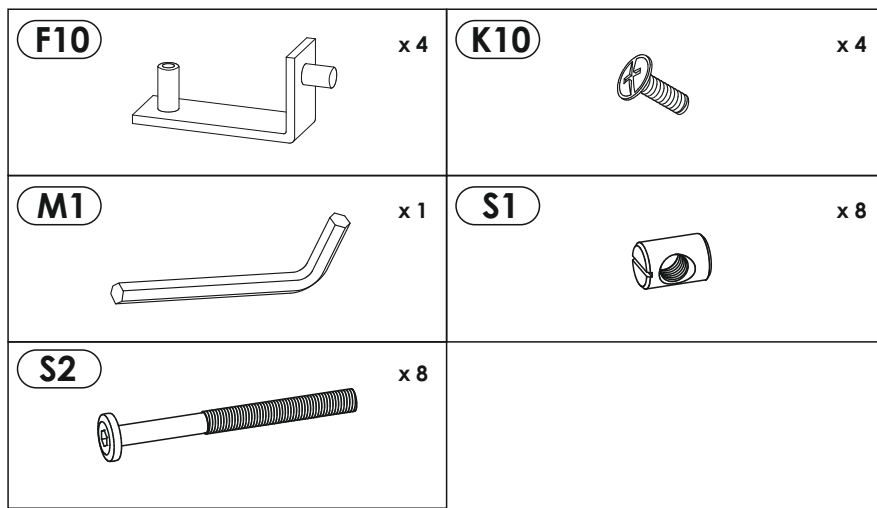
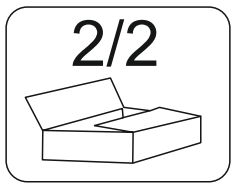
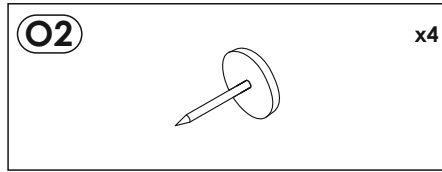
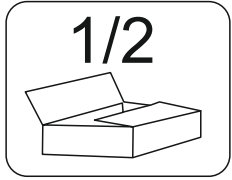
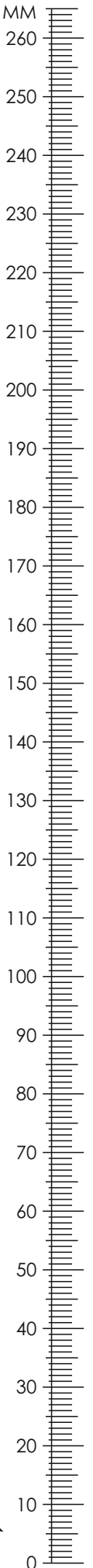

ANGEL TYP98

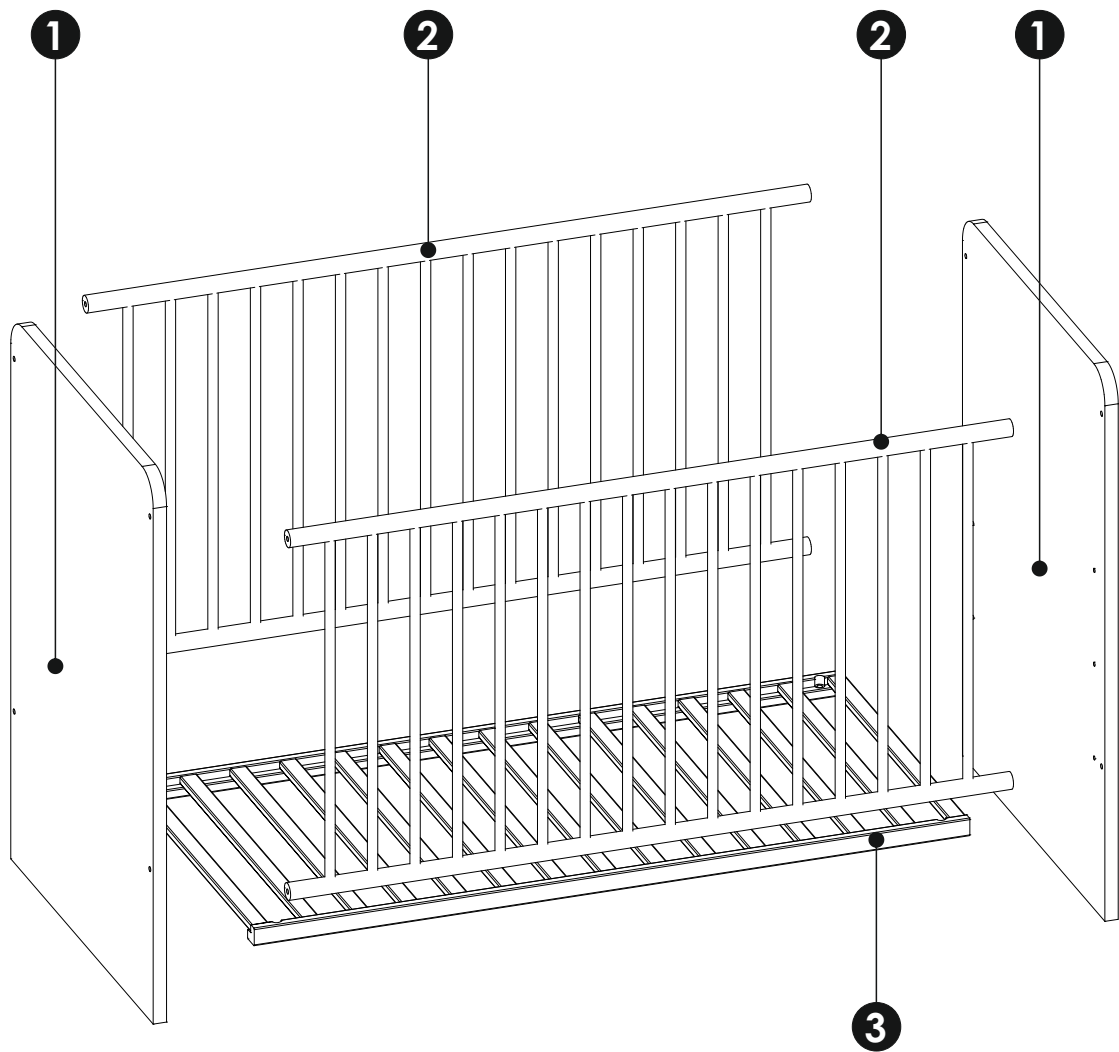

1	930	644	22	x2	1/2
2	1190	630	x2	2/2	
3	1178	580	x1	2/2	



x2

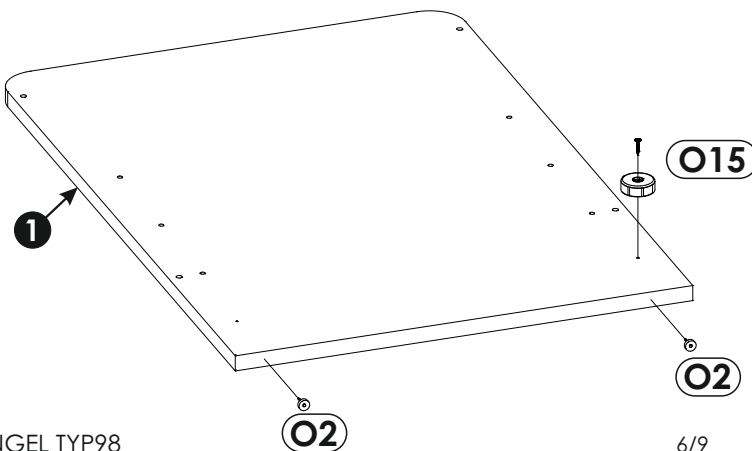
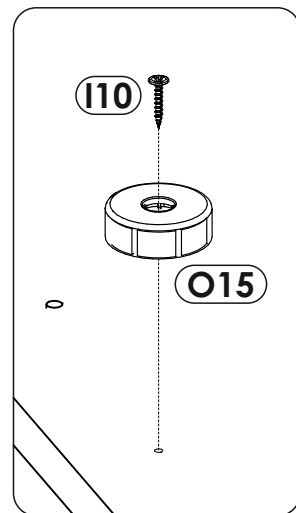
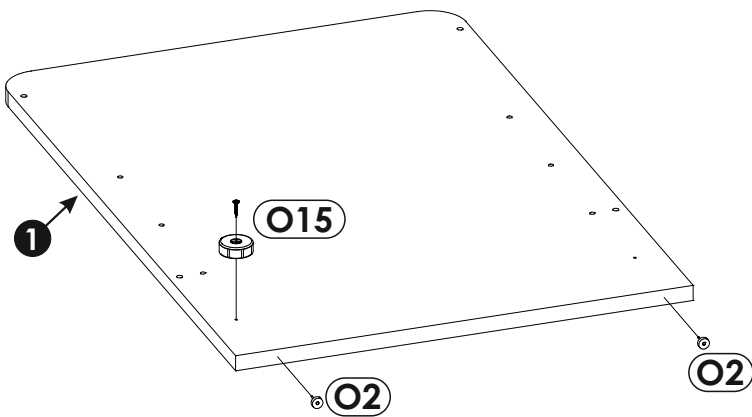
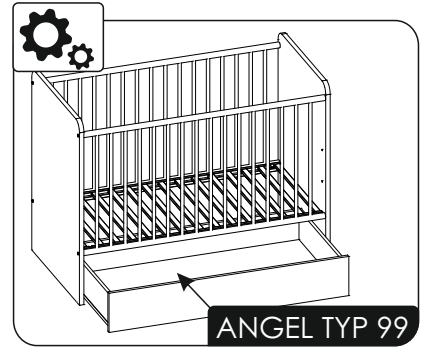
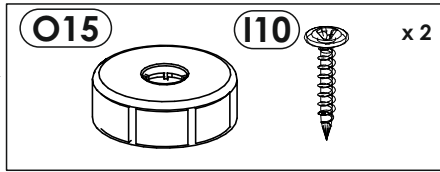
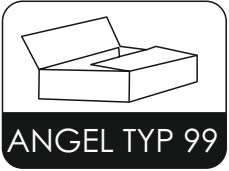
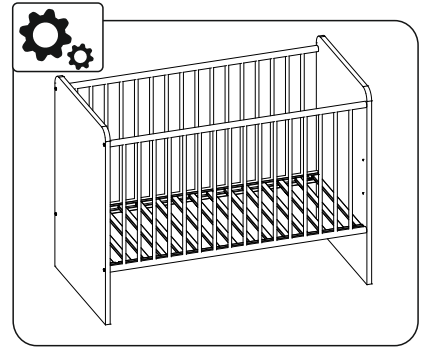
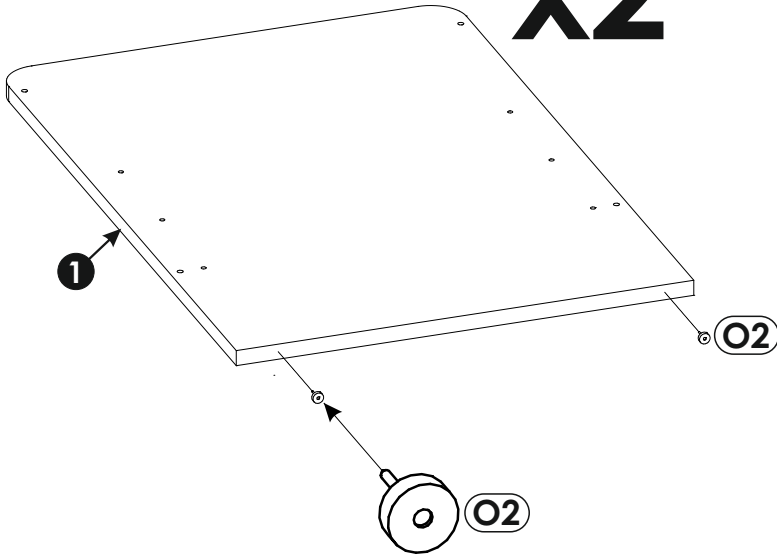

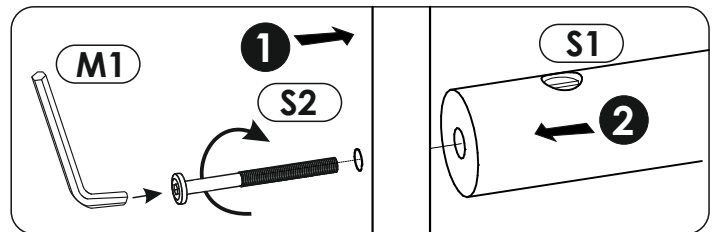
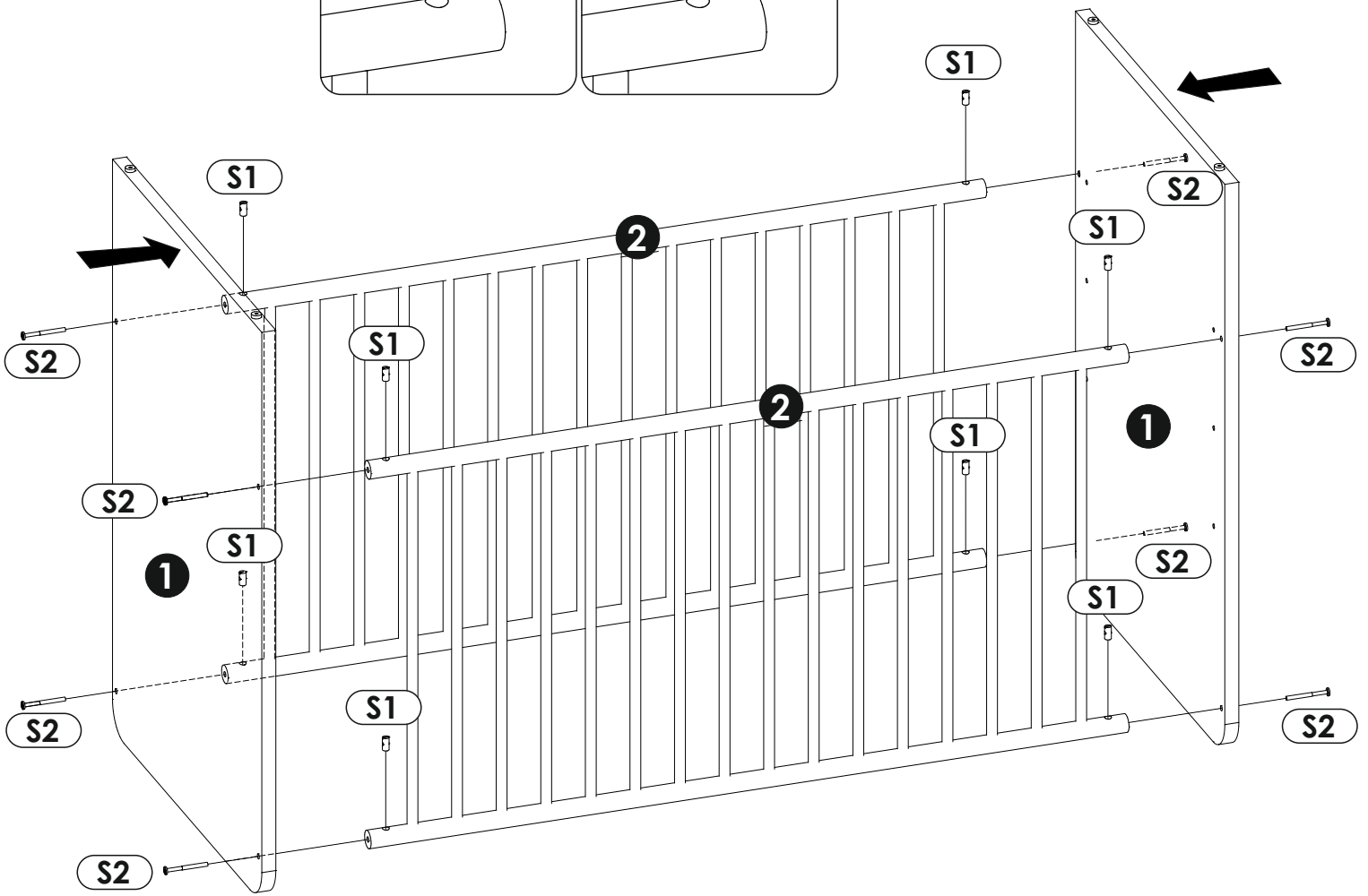
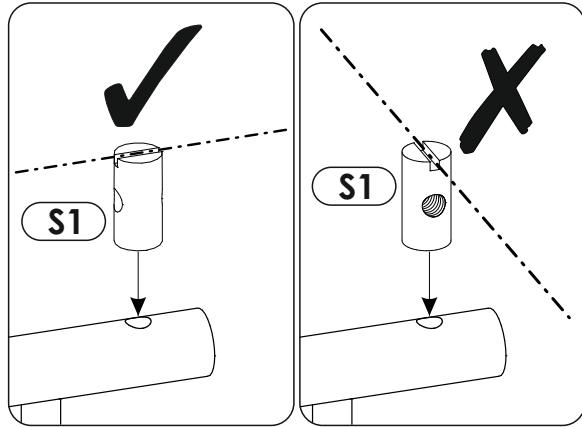

3 ▶

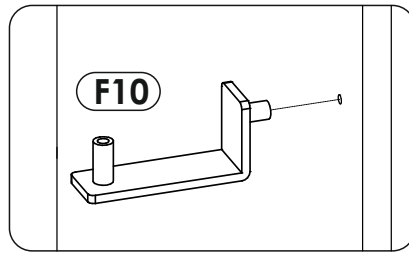
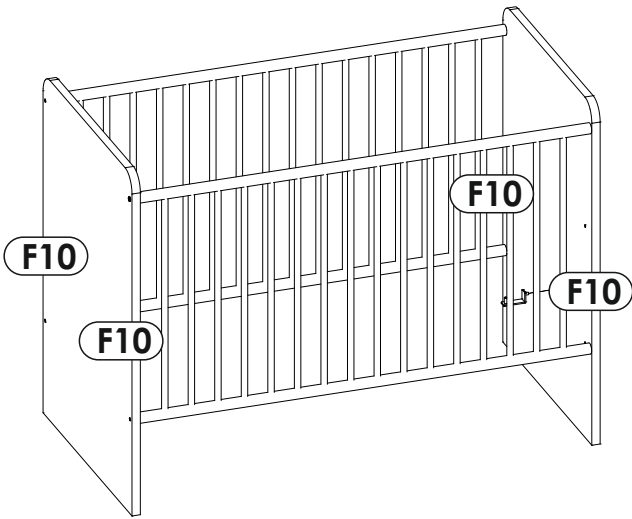

4 ▶

