

8x a132	2x a44	2x b19	8x b43	5x c235	16x d1	4x d3	26x e1	22x e2	4x e5	4x e4	32x f1	20x f6
8x f35	2x g2	11x k43	12x l1	48x l2	2x m3	10x n108	2x n122/1	2x o1	6x p1	8x p9	4x p21	2x p59
20x p51	10x p55	81x r1	81x r42	4x s1	22x s2	1x z1	2x n14	8x p17	4x p38	2x n10		

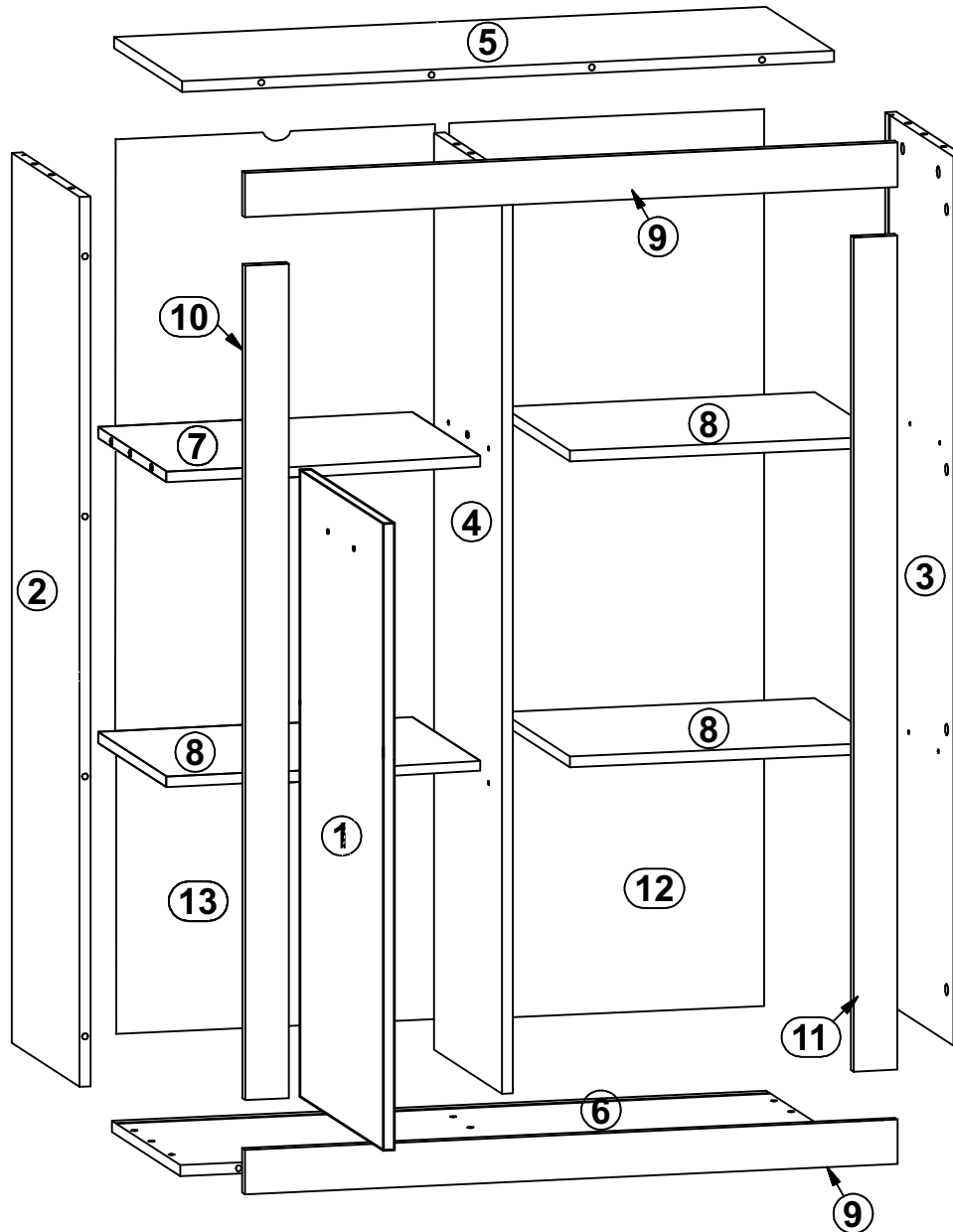

A	B	C (mm)		D
1	N76-001	536	258	3/4
2	N76-101	880	284	3/4
3	N76-102	880	284	3/4
4	N76-107	880	264	3/4
5	N76-201	631	284	3/4
6	N76-202	631	284	3/4
7	N76-301	291	264	3/4
8	N76-302	291	264	3/4
9	N76-501	631	60	3/4
10	N76-502	793	60	3/4
11	N76-503	793	60	3/4
12	N76-901	890	304	3/4
13	N76-902	890	304	3/4

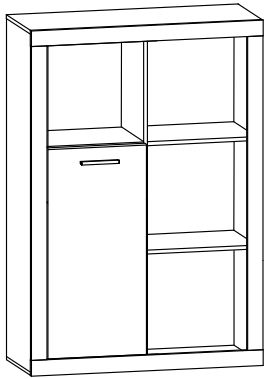
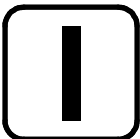

1 

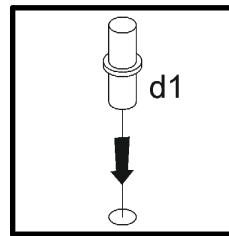
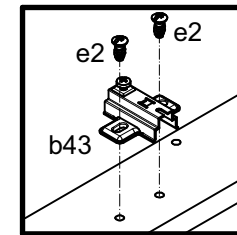
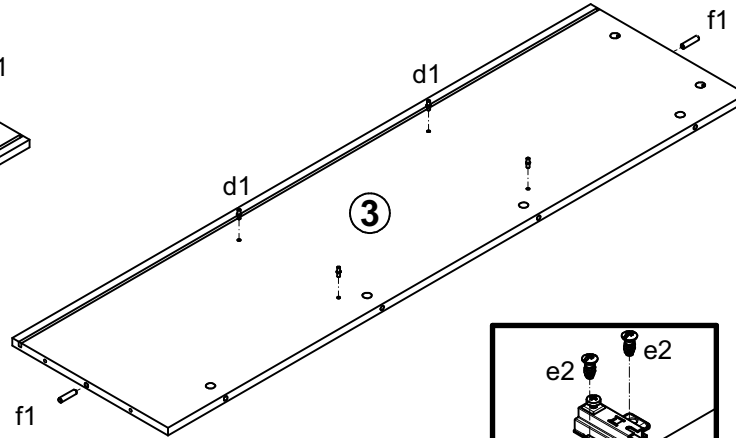
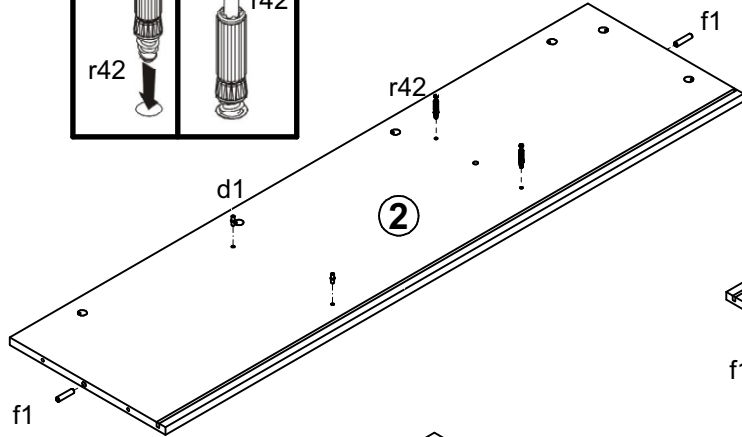
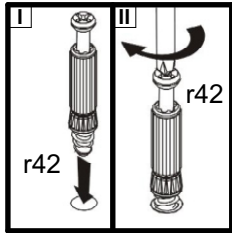

2 

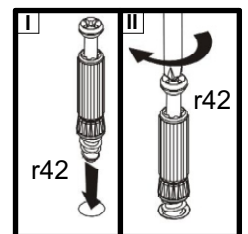
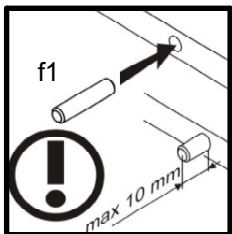
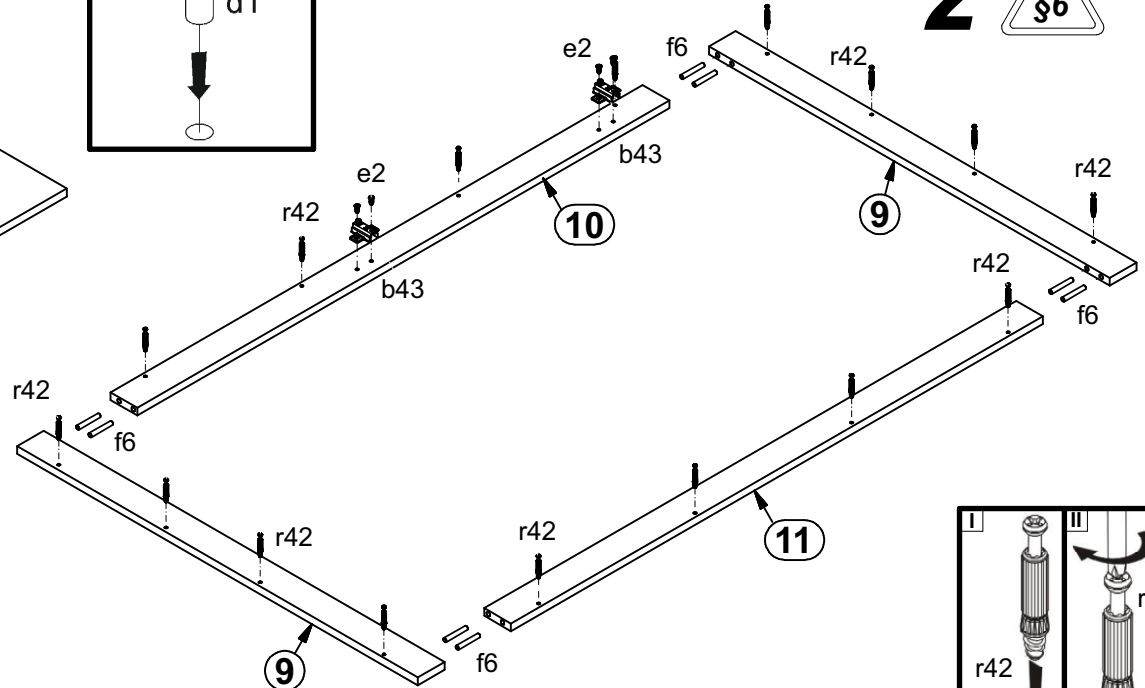
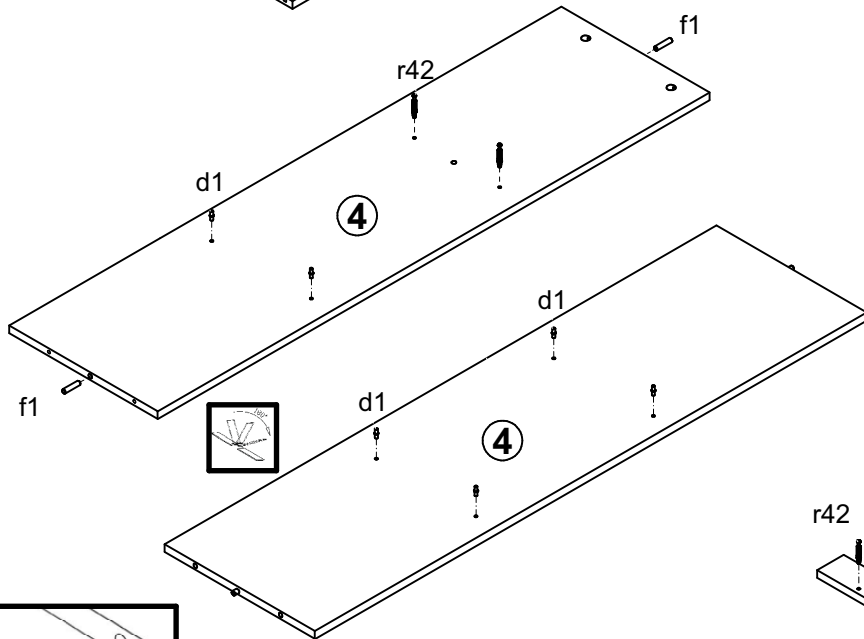

3

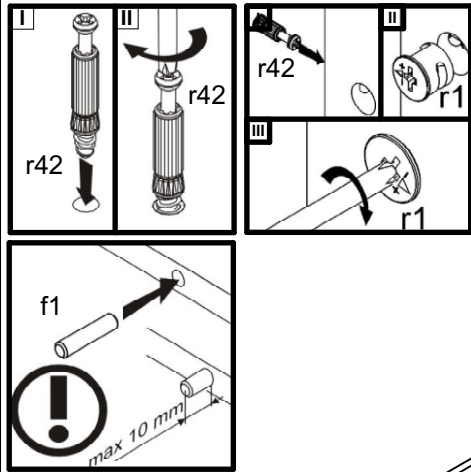

4

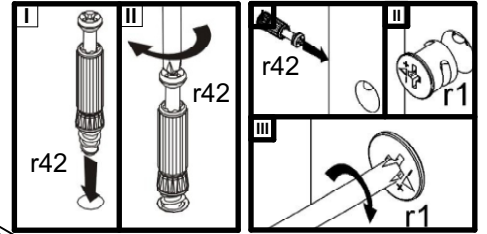
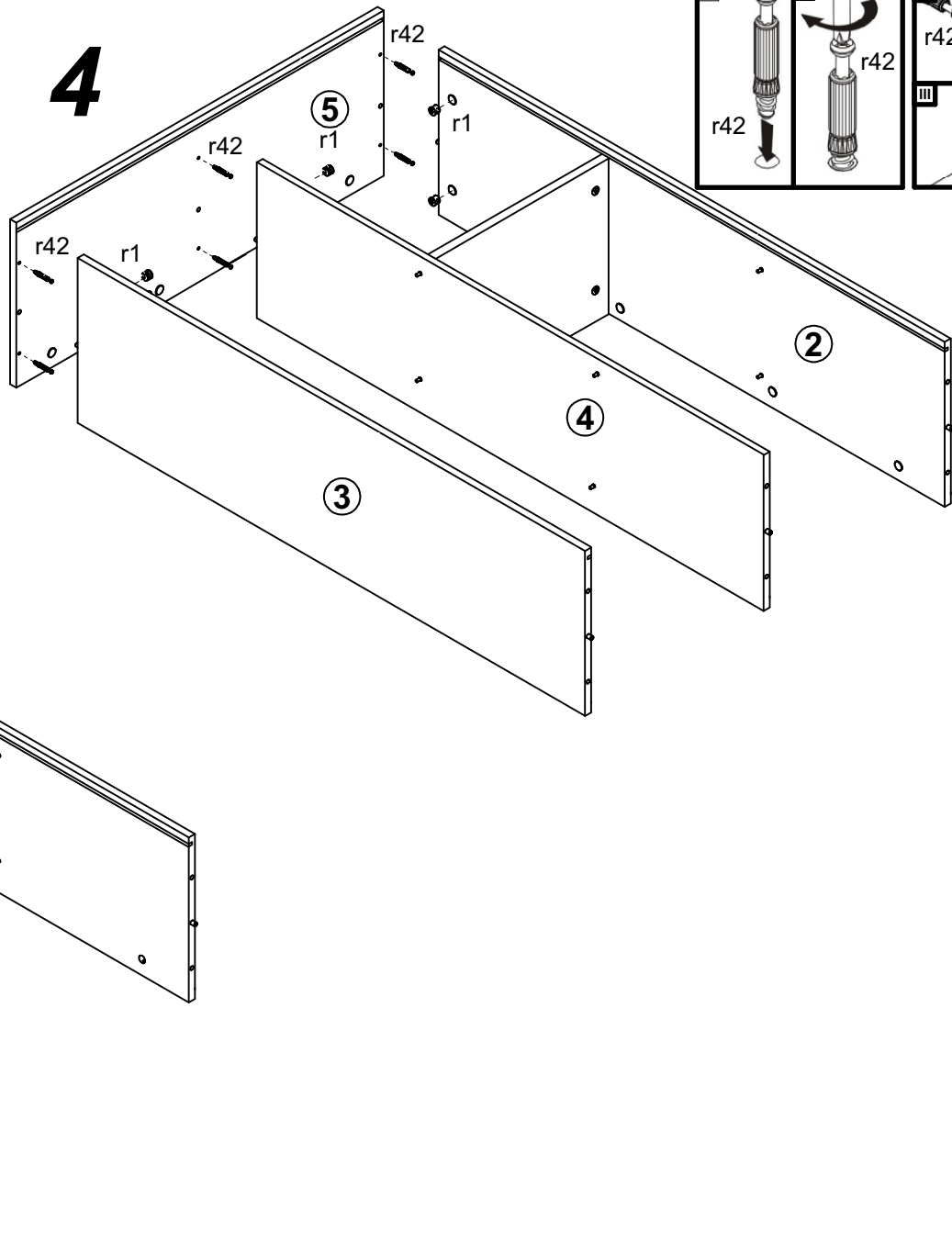

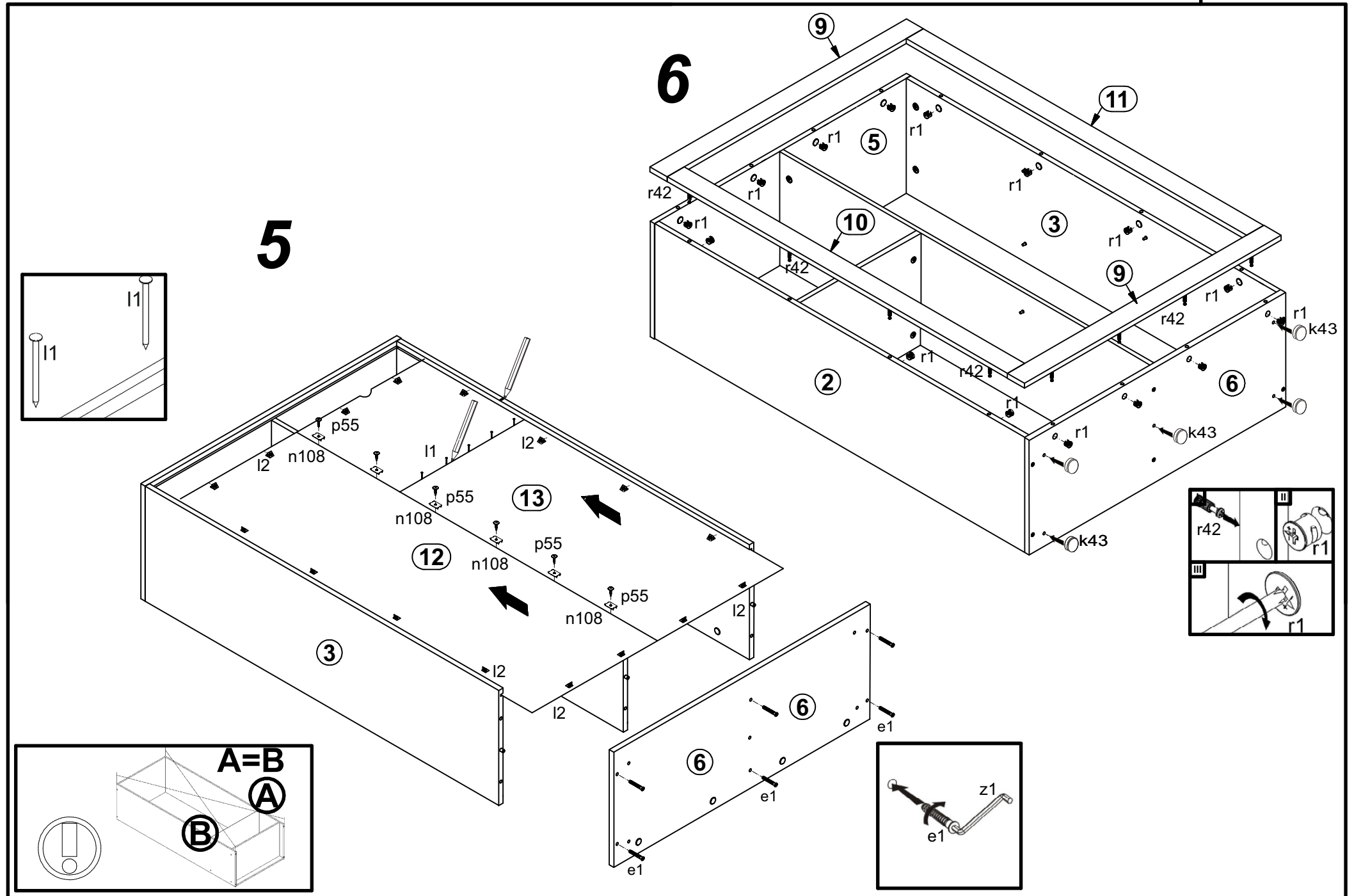

7

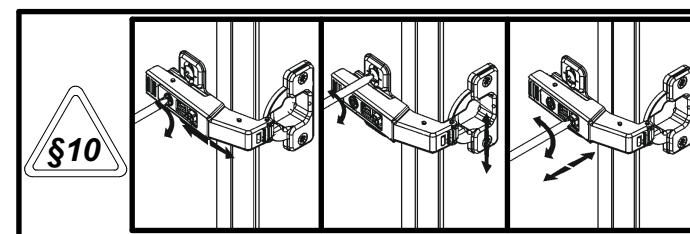
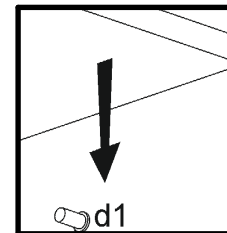
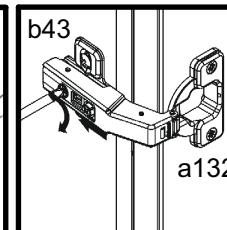
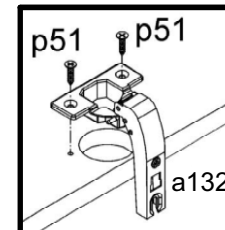
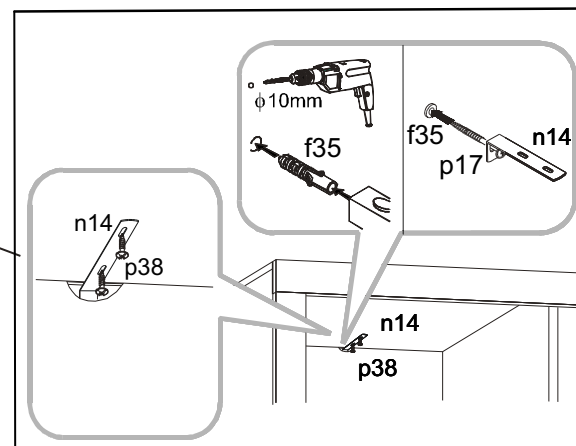
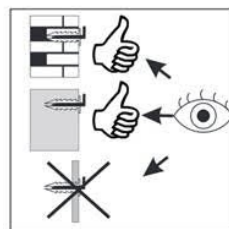
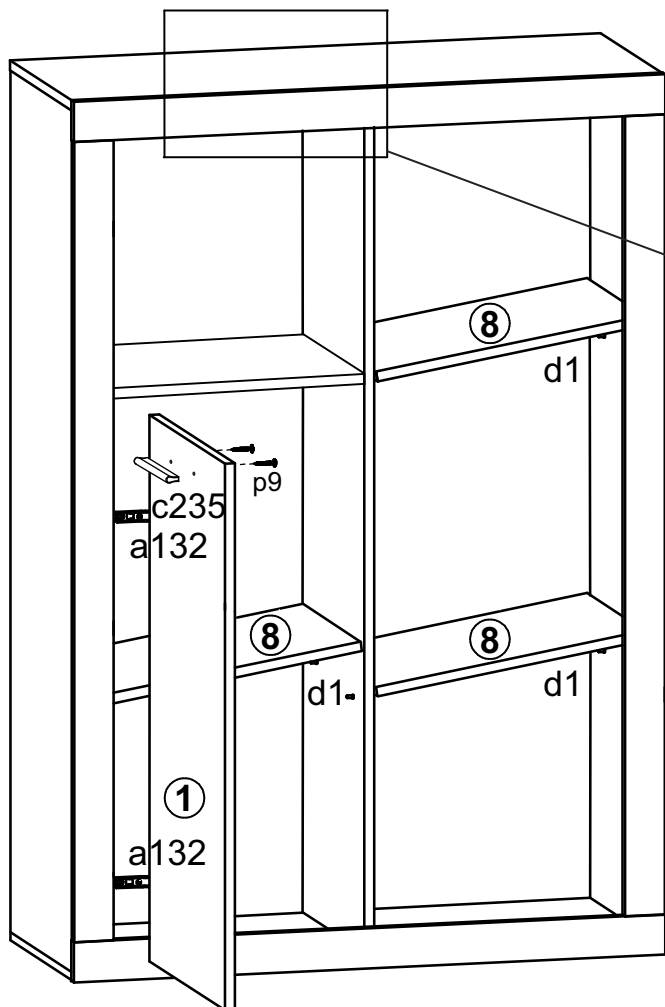

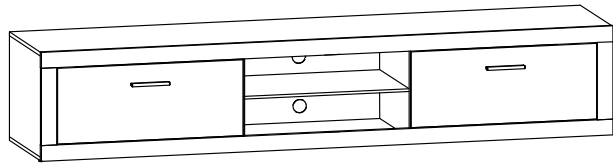

A	B	C (mm)		D
1	N76-004	407	205	1/4
2	N76-005	407	205	1/4
3	N76-107	298	380	2/4
4	N76-108	298	380	2/4
5	N76-109	298	360	2/4
6	N76-110	298	360	2/4
7	N76-204	1400	380	1/4
8	N76-205	1400	380	1/4
9	N76-303	445	360	1/4
10	N76-510	1400	60	1/4
11	N76-512	211	60	1/4
12	N76-511	1400	60	1/4
13	N76-905	1377	308	1/4

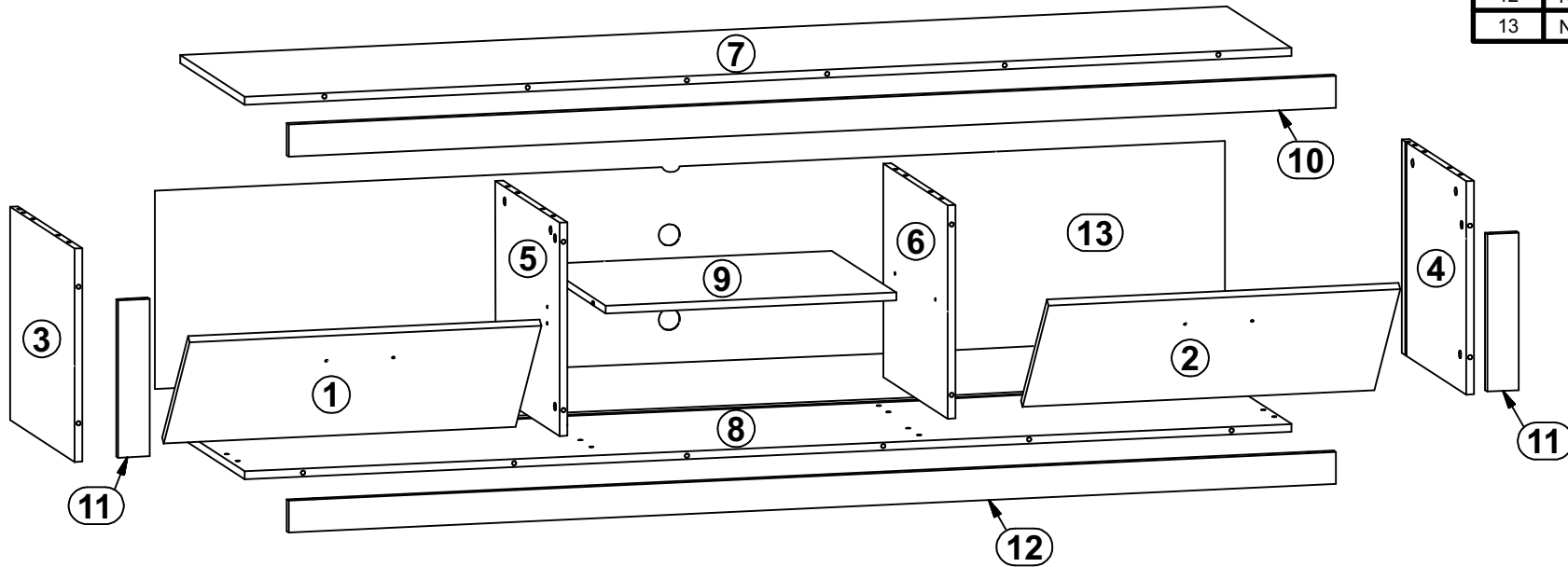

8 

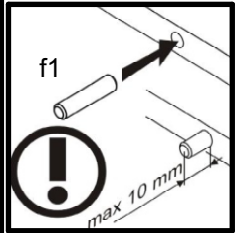
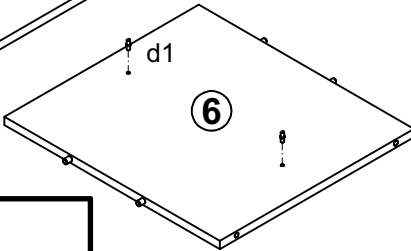
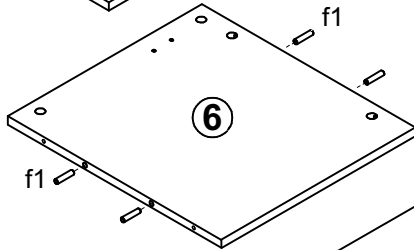
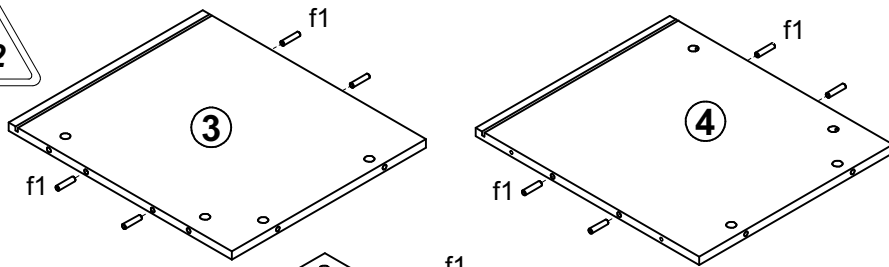

9 

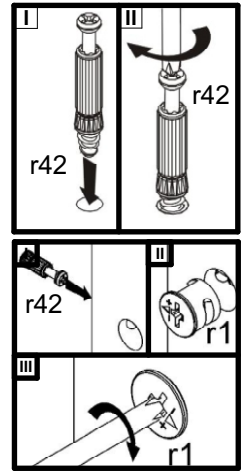
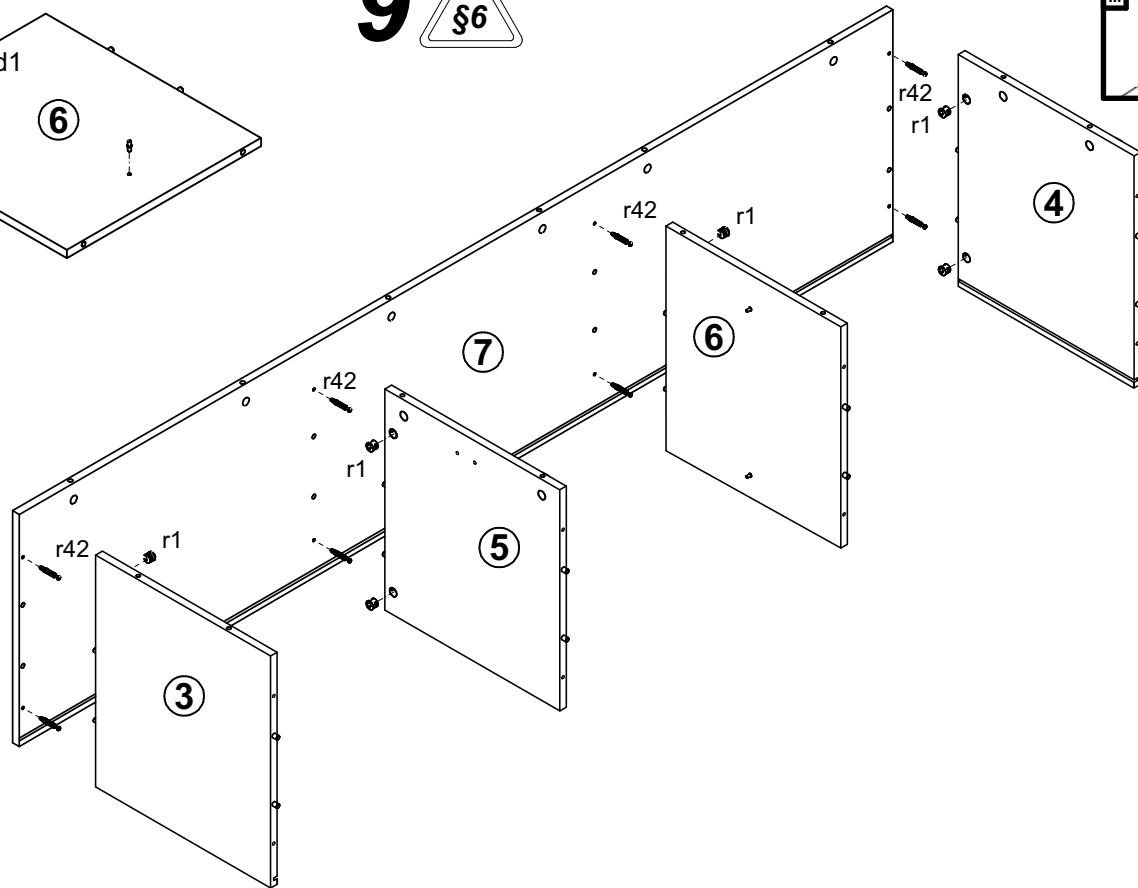
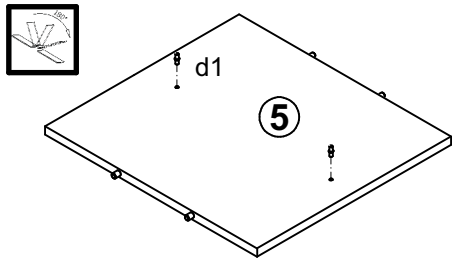
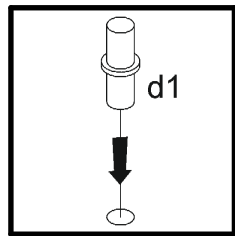
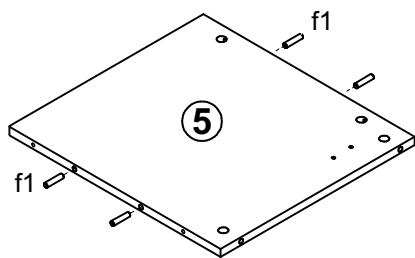

10

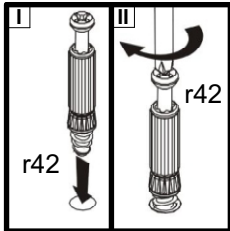
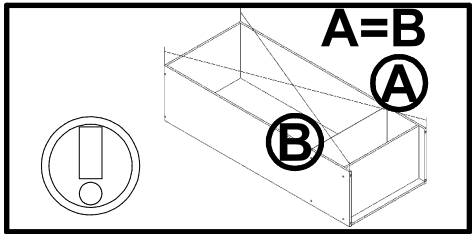
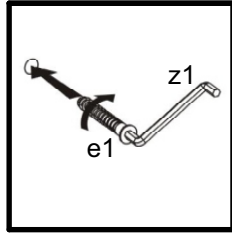
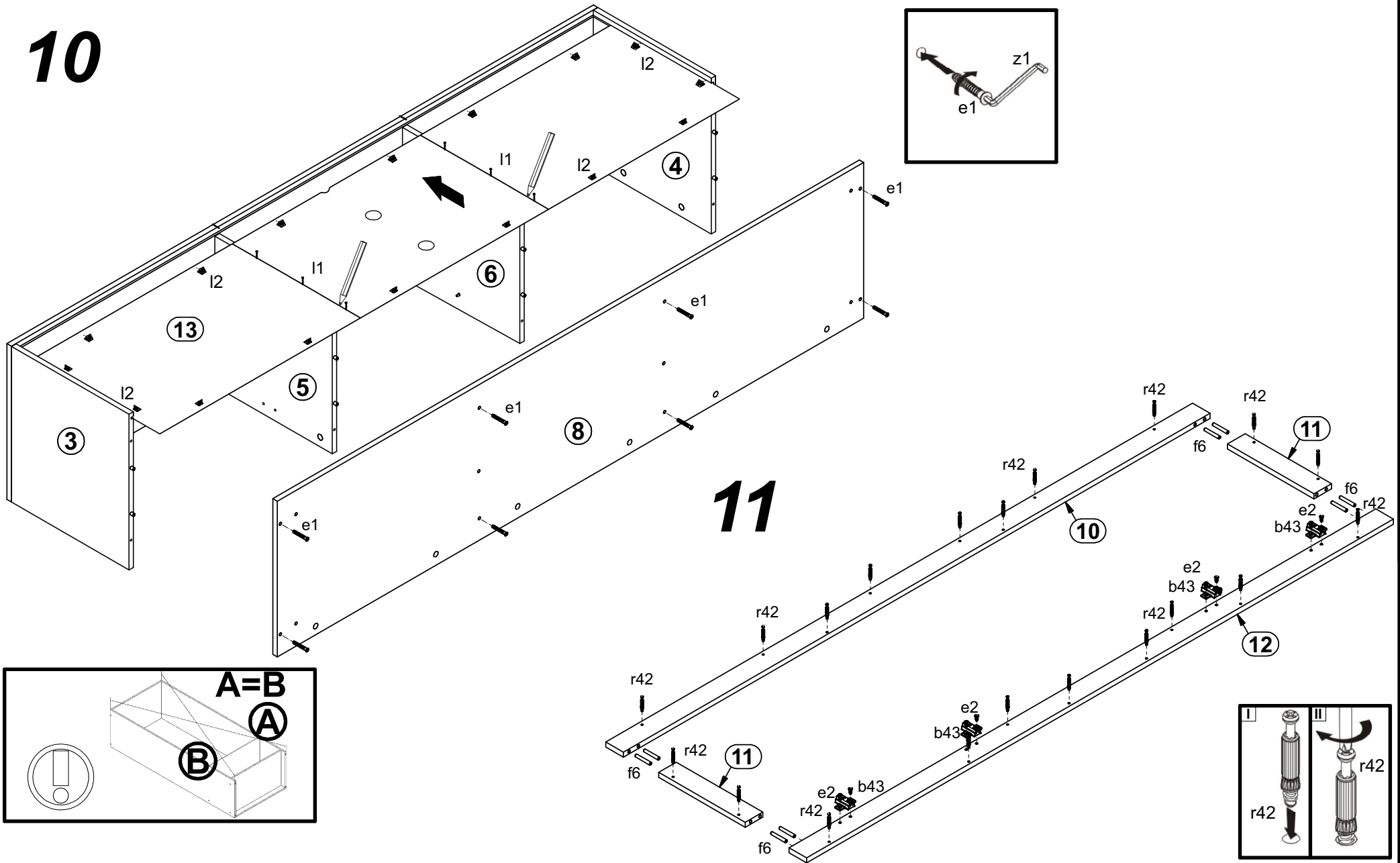

12

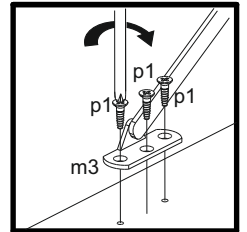
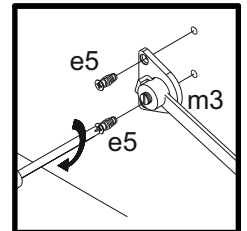
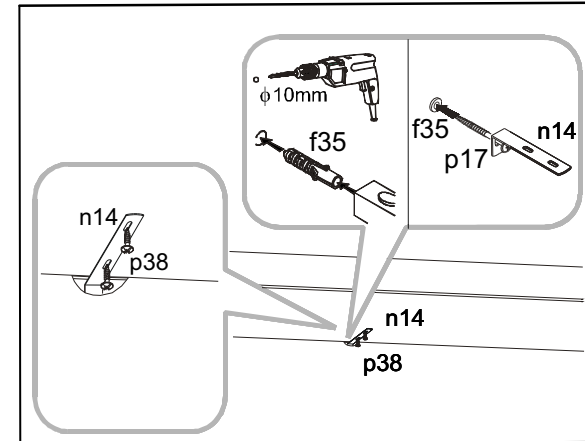
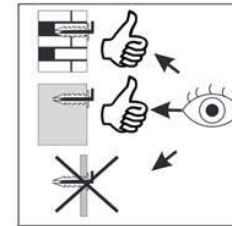
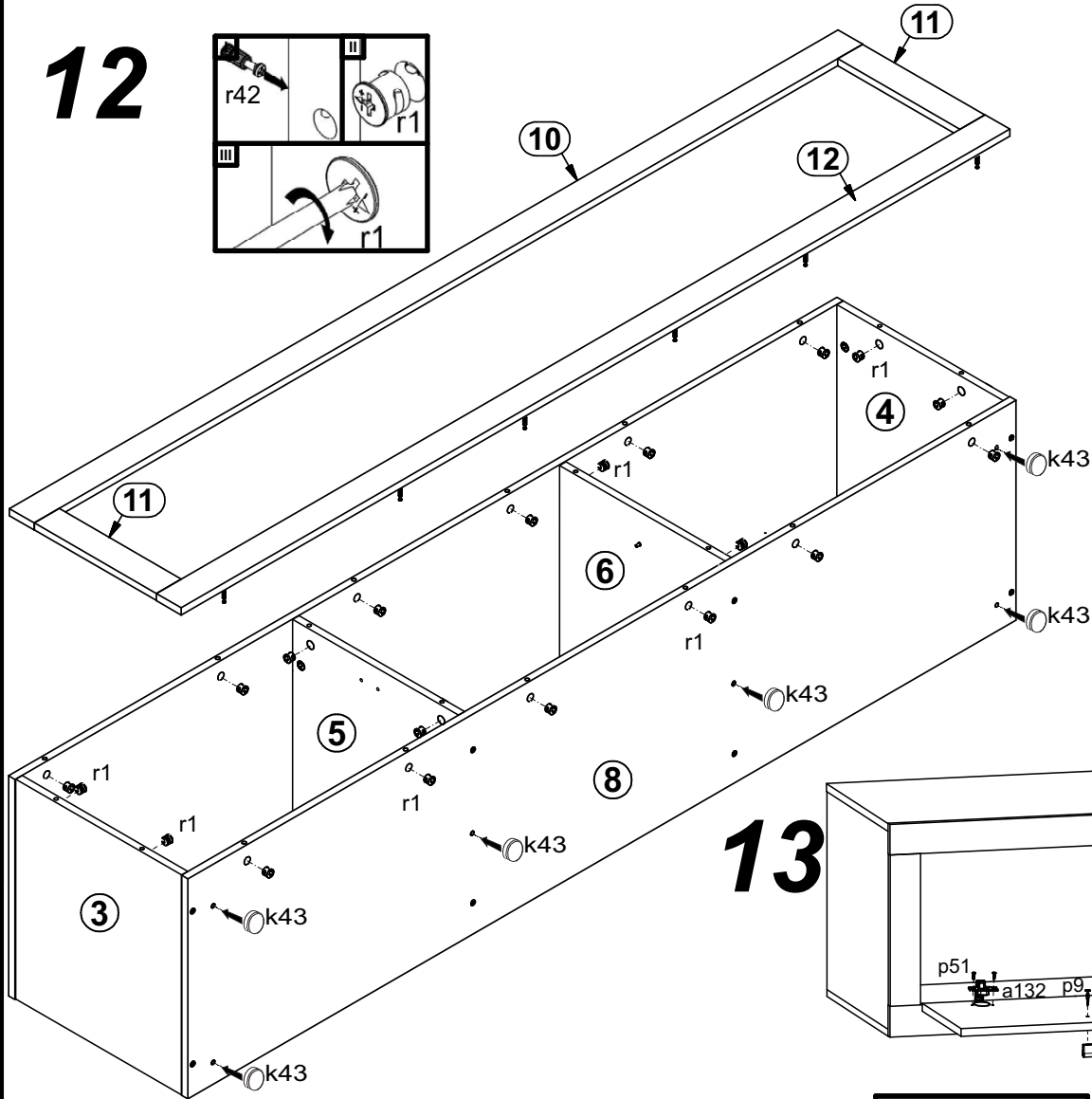
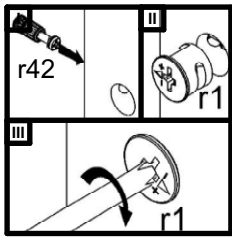

13

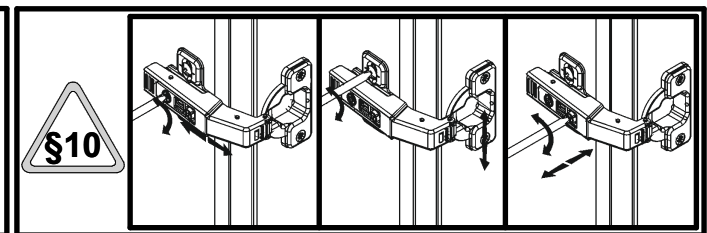
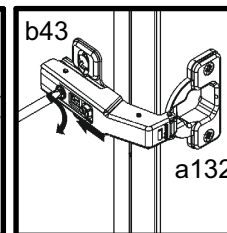
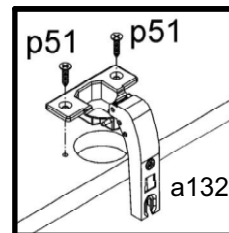
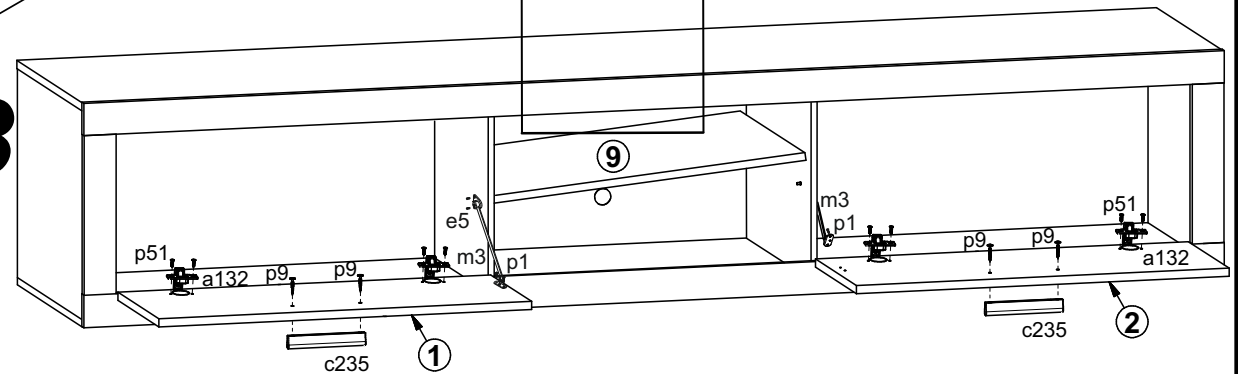



A	B	C (mm)		D
1	N76-002	655	252	4/4
2	N76-003	655	313	4/4
3	N76-104	748	284	4/4
4	N76-106	748	284	4/4
5	N76-105	748	264	4/4
6	N76-203	631	284	4/4
7	N76-201	631	284	4/4
8	N76-301	291	264	4/4
9	N76-505	631	60	4/4
10	N76-506	631	60	4/4
11	N76-508	290	256	4/4
12	N76-504	661	60	4/4
13	N76-903	758	304	4/4
14	N76-904	758	304	4/4

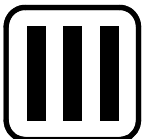
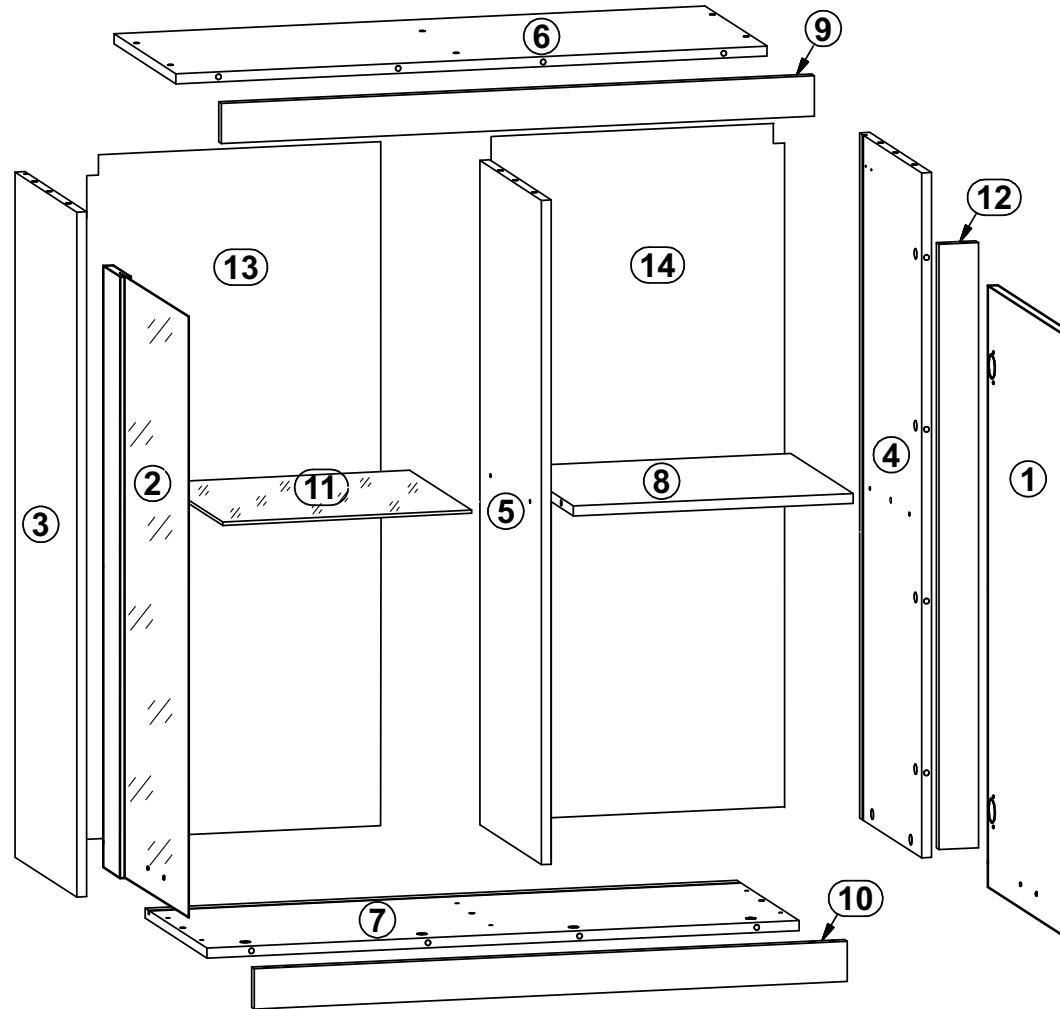
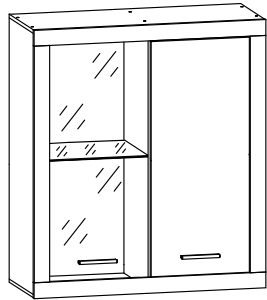

14

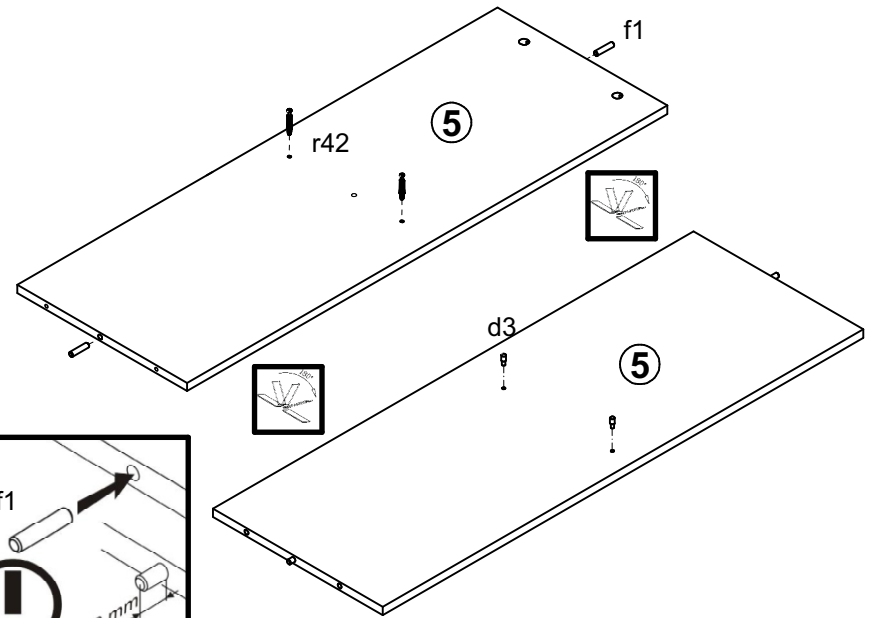
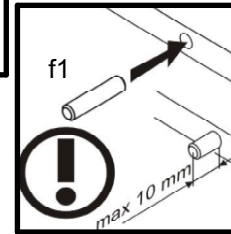
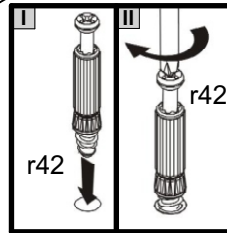
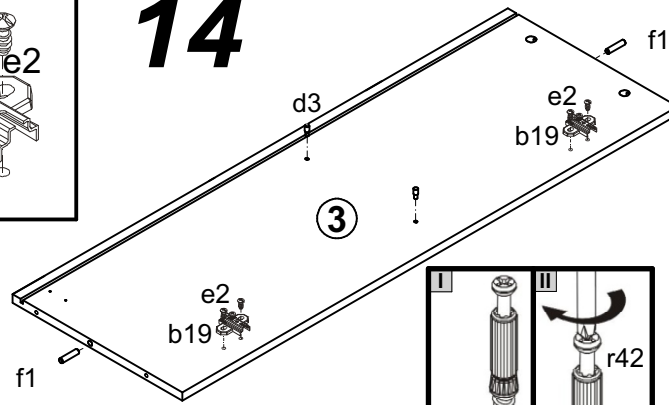
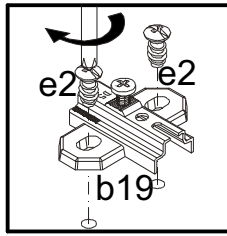
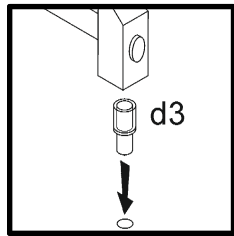

15

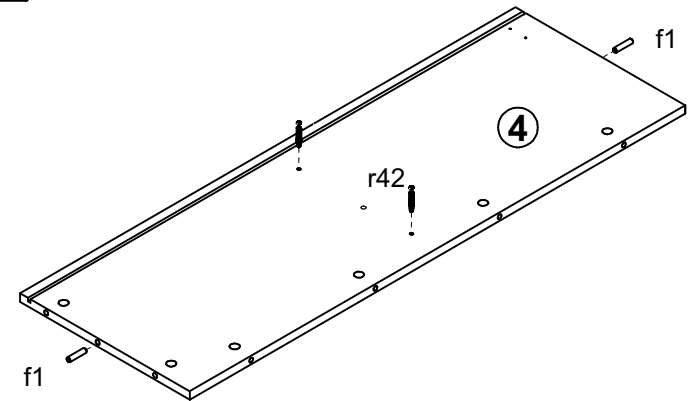
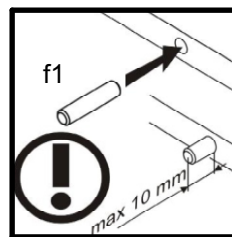
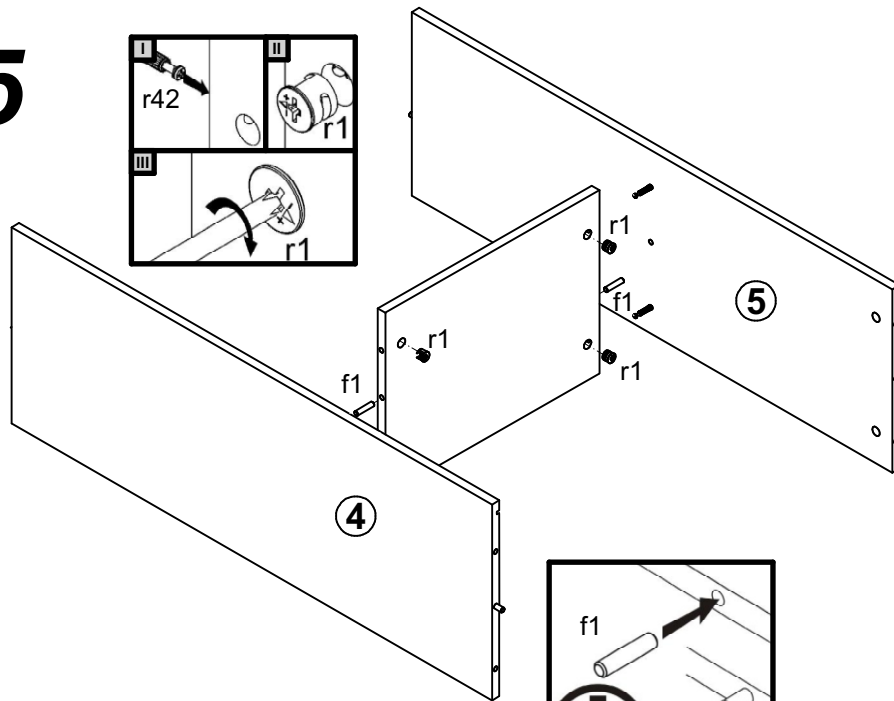
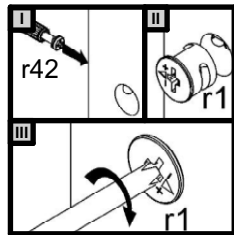

17

16

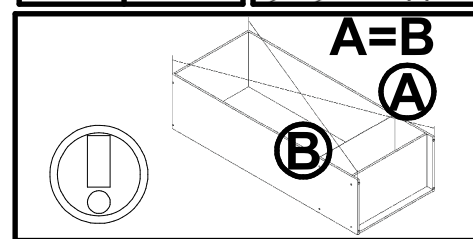
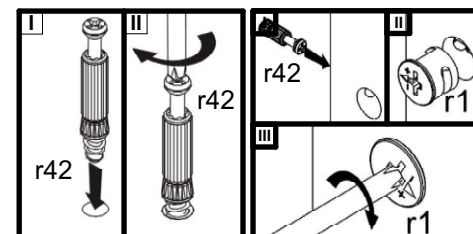
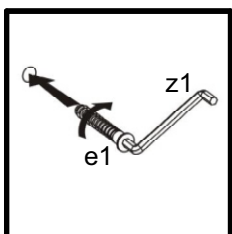
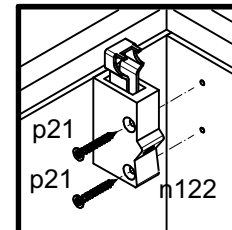
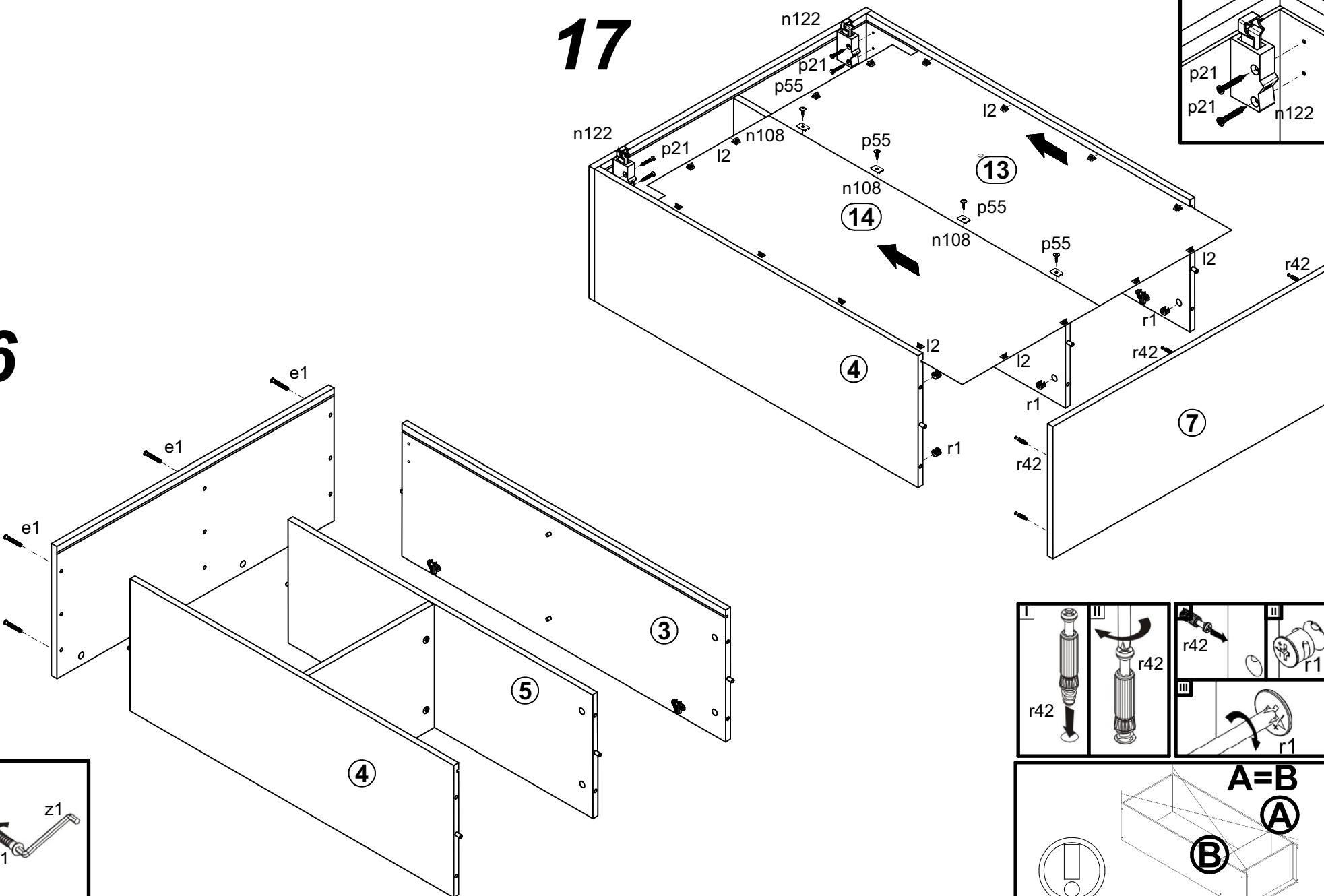

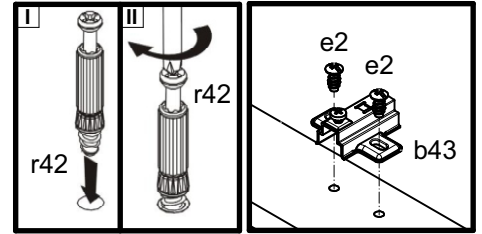

18

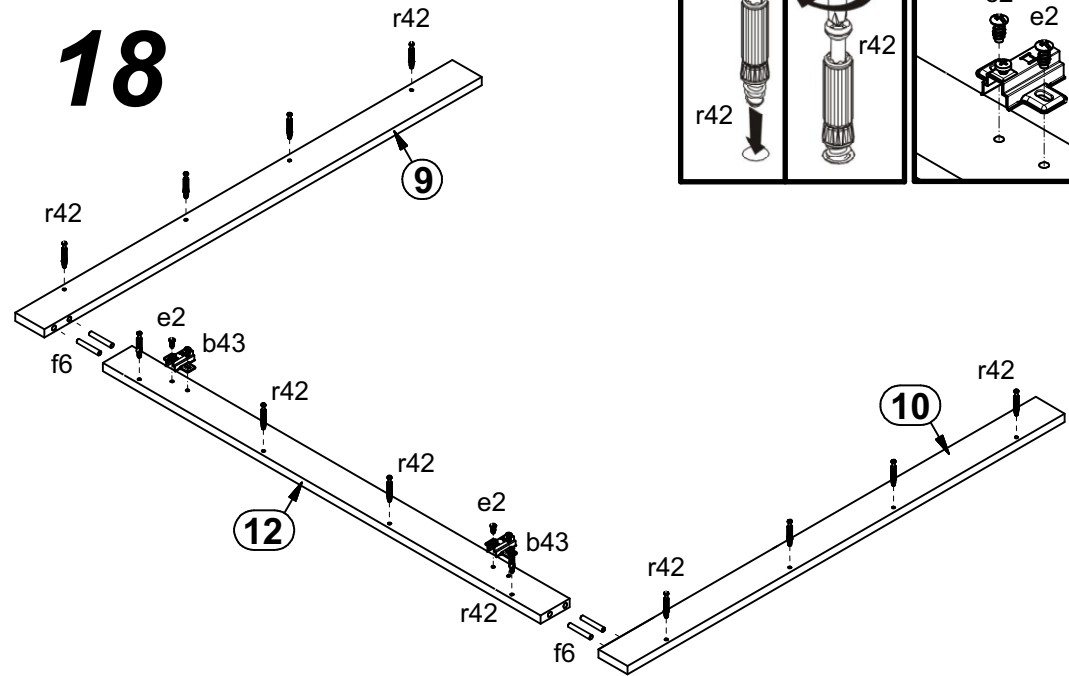

19

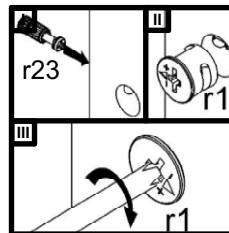
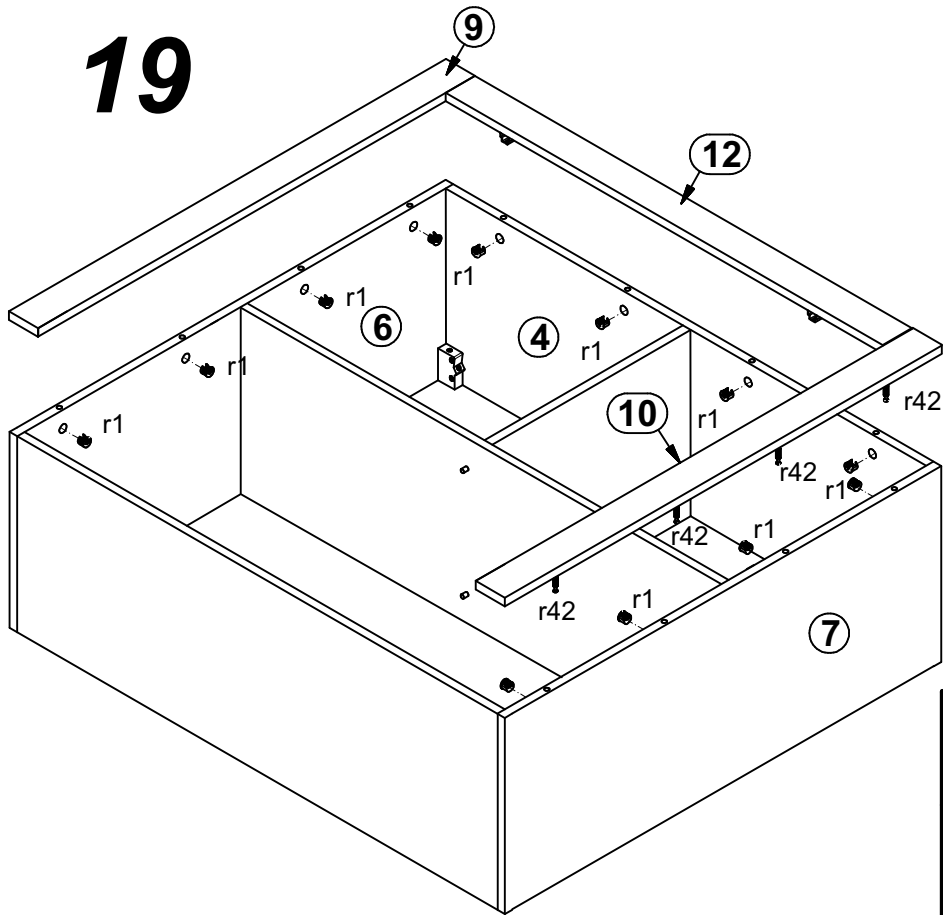

20

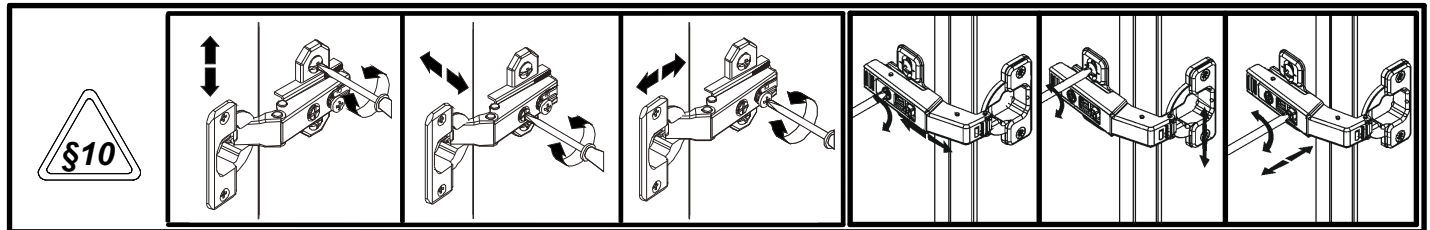
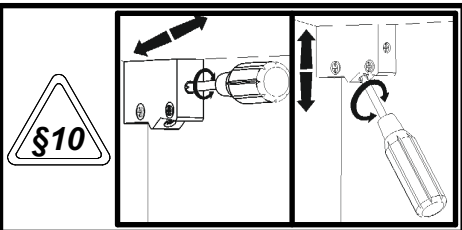
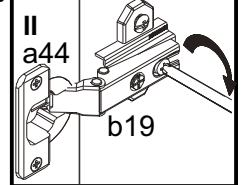
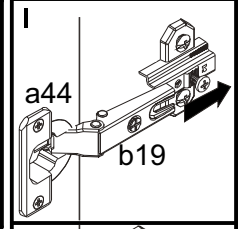
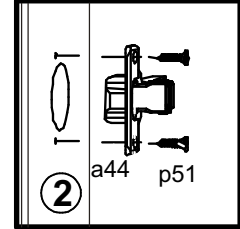
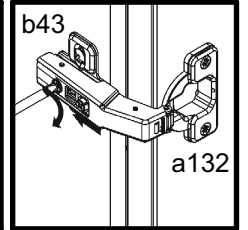
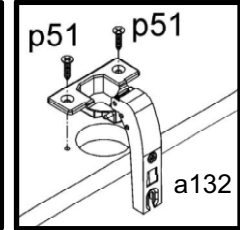
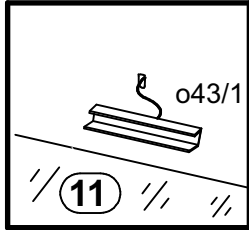
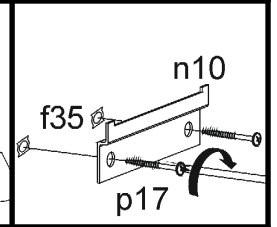
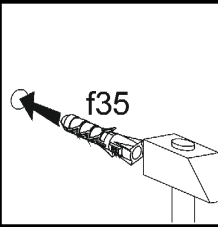
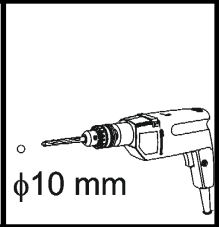
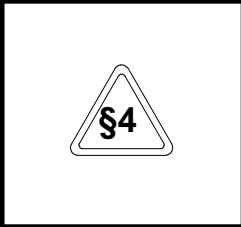
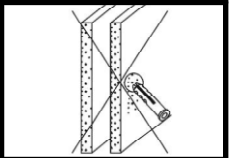
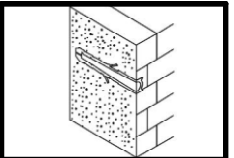
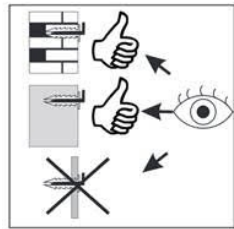
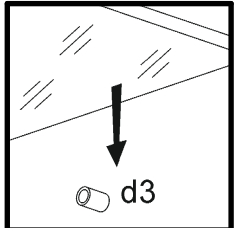
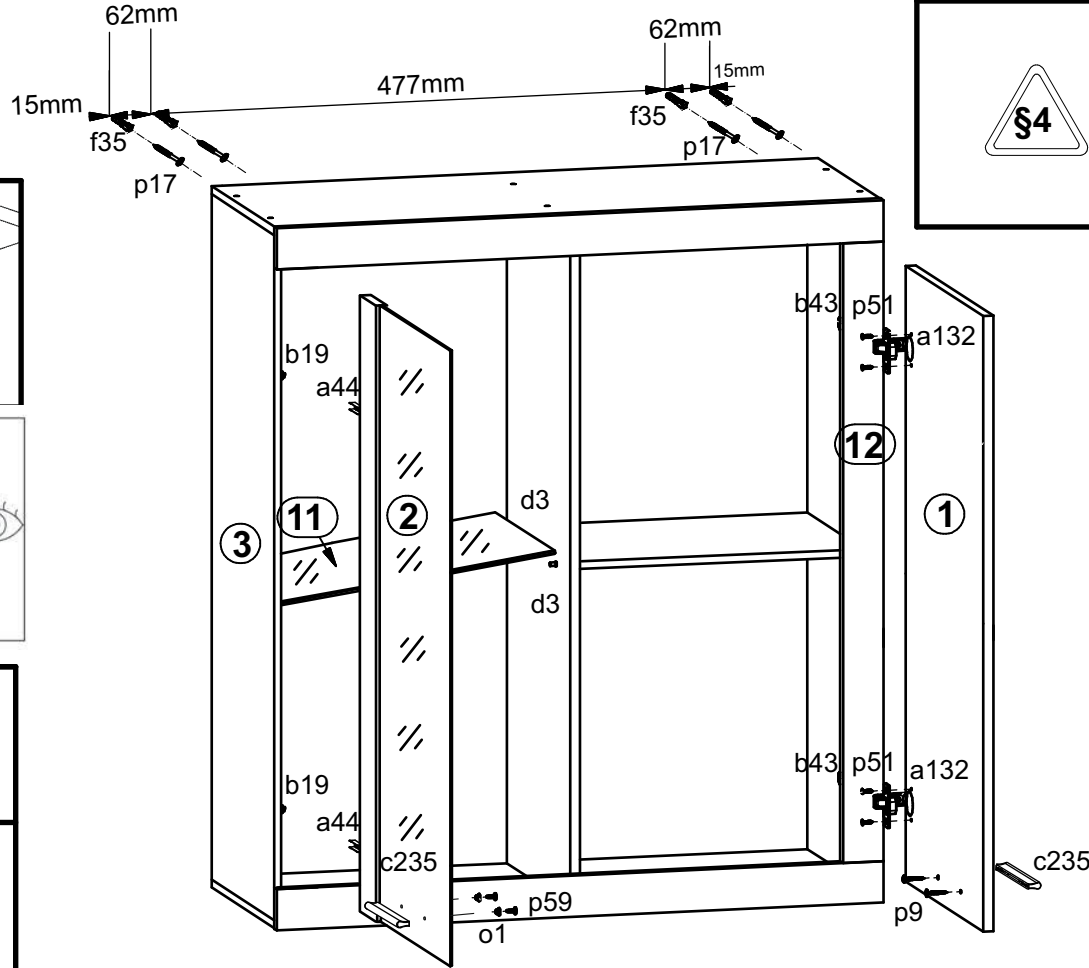

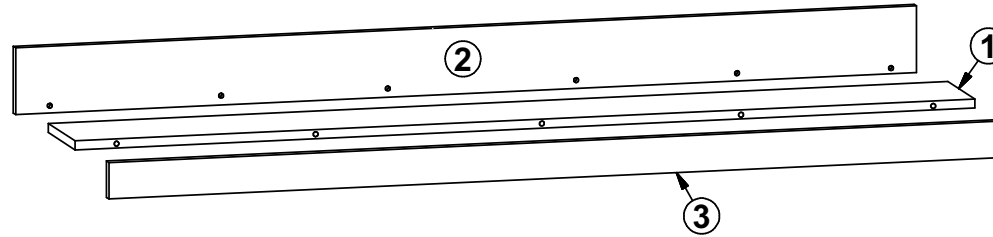

A	B	C (mm)		D
1	N76-304	1000	138	2/4
2	N76-513	1000	108	2/4
3	N76-514	1000	60	2/4

21

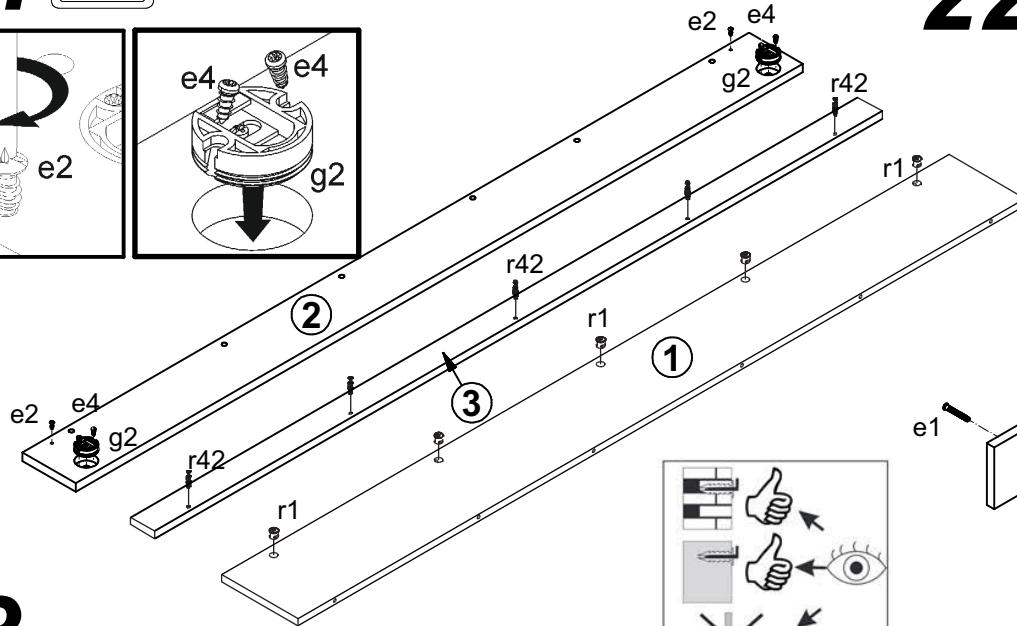
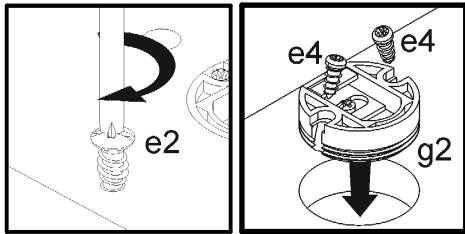

22

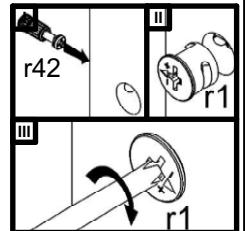
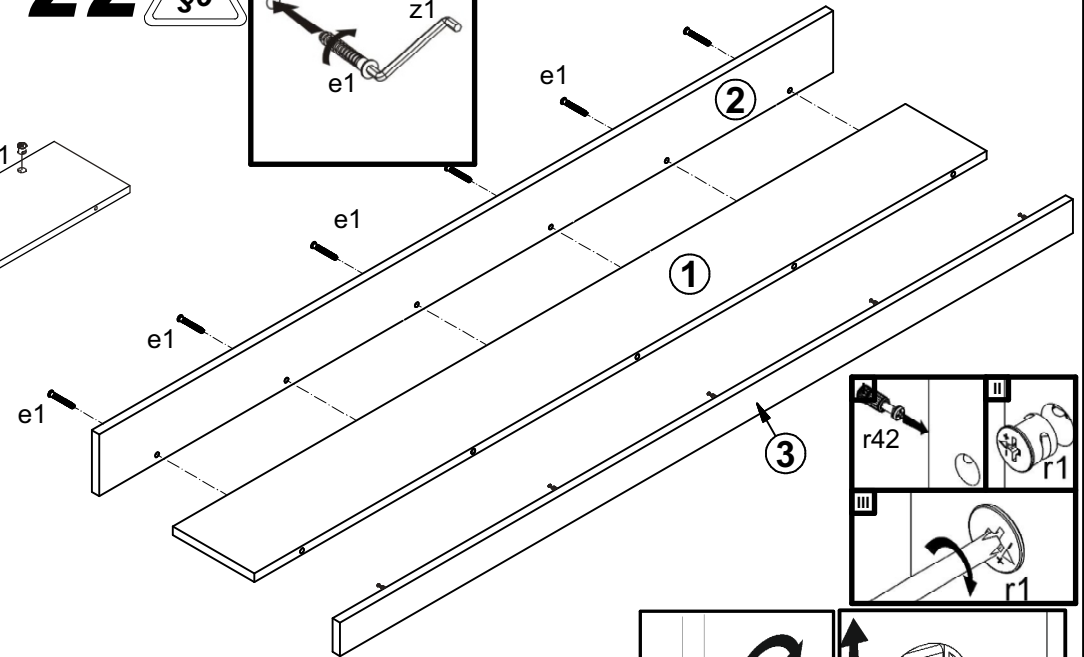
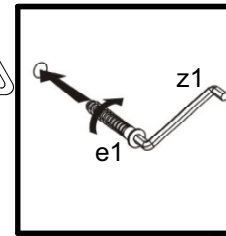

23

