

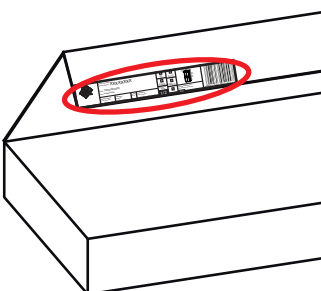

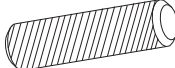

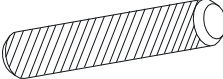

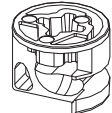

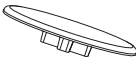

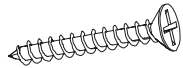

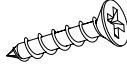

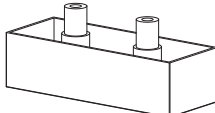
PL - Zachowaj w razie reklamacji !!! / BG - Пазете в случай на рекламация !!! / CZ - Uchovávejte pro případ stížnosti !!! / DE - Bewahren Sie das Etikett für Reklamationen !!! / ENG - Keep the label for complaints !!! / ES - Conservar en caso de reclamación !!! / EST - Kaebuse korral hoidke alles !!! / FR - Conserver en cas de réclamation !!! / HR - Zadržite u slučaju prigovora !!! / HU - Tartsa fenn panasz esetén !!! / IT - Conservare in caso di reclamo !!! / LT - Laikykite skundo atveju !!! / LV - Saglabājiēt sūdzības gadījumā !!! / NL - Bewaren in geval van een klacht !!! / PO - Guardar em caso de reclamação !!! / RO - Păstrați în cazul unei reclamații !!! / RU - Сохранить в случае рекламации !!! / S - Föörvara vid klagomål !!! / SK - Majte v prípade reklamácie !!! / SLO - Hranite v primeru pritožbe !!! / SRB - Задржите у случају жалбе !!! / TR - Şikayet durumunda saklayın !!! / UKR - Зберігати у разі скарги !!!

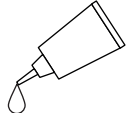

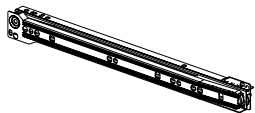
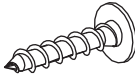
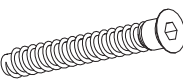
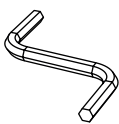

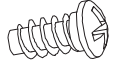
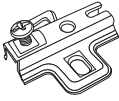
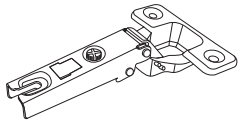
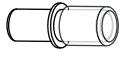

Nazwa wyrobu: Product Name: XXXXXXXXXX			
Kolor: XXXXXXXXXX Color:XXXXXXXXXX			
Data produkcji: Production date:	Pakujący: Packager:	Szkló: Glass:	Kod paczki: Code packages:
0000-00-00	xx0/xx0	0	0xxxxx00-000-0/0

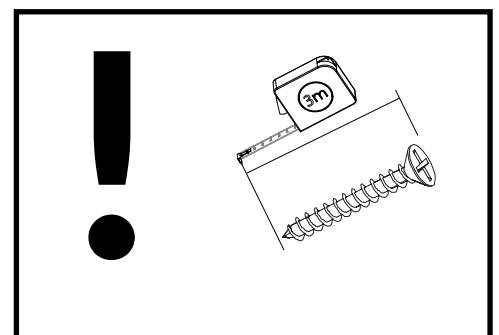



BLANCO 10

<p>K1 x 20 8x32</p> 	<p>K2 x 8 8x60</p> 	<p>B2 x 20 h-12</p> 
<p>ZM1 x 20 Ø18</p> 	<p>WT1 x 12 3,5x15</p> 	<p>WT24 x 5 4x40</p> 
<p>ZJ1 x 20 L-43</p> 	<p>WT35 x 6 3x20</p> 	<p>GW1 x 42 1,4x25</p> 
<p>ST2 x 5</p> 	<p>DS2 x 5</p> 	<p>KL x 1</p> 
<p>WS1 x 1</p> 	<p>P5 x 1</p> 	<p>WT9 x 6 3x13</p> 
<p>KT1 x 8 6,3x50</p> 	<p>x 1</p> 	<p>PO2 x 4 Ø5</p> 
<p>WE2 x 4 6,3x13B</p> 	<p>PK1 x 2 H-0</p> 	<p>ZP5 x 2</p> 
<p>PO3 x 4 Ø5</p> 	<p>BR1 x 4</p> 	



BLANCO 10

	CODE				
1	Blanco10_08	156	350	2	2/2
2	Blanco10_06	707	398	1	1/1
3	Blanco10HDF_03	677	355	1	2/2
4	Blanco10_11	409	537	1	1/2
5	Blanco10_13	727	115	1	2/2
6	Blanco10_12	537	115	1	2/2
7	Blanco10HDF_02	1269	226	1	2/2
8	Blanco10HDF_01	1269	300	1	2/2
9	Blanco10_07	515	390	1	1/2
10	Blanco10_05	498	399	1	1/2
11	Blanco10_09	650	156	1	2/2

	CODE				
12	Blanco10_03	498	399	1	1/2
13	Blanco10_04	498	399	1	1/2
14	Blanco_01	350	40	1	2/2
15	Blanco_02	450	40	1	2/2
16	Blanco10_02	1274	400	1	2/2
17	Blanco10_01	1274	400	1	2/2
18	Blanco10_10	727	115	1	2/2
19	4SZKL-5NR38	706	384	1	1/2

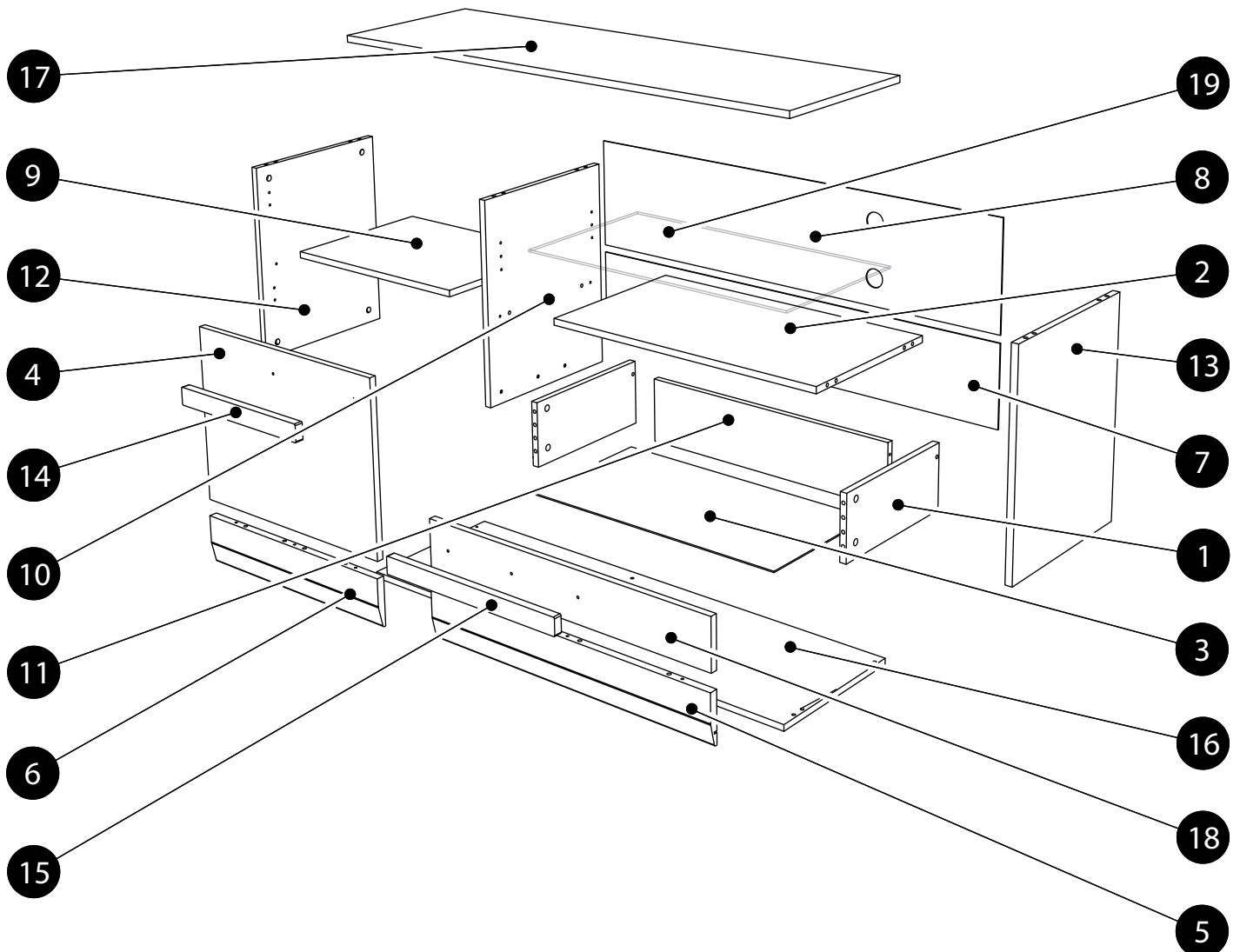

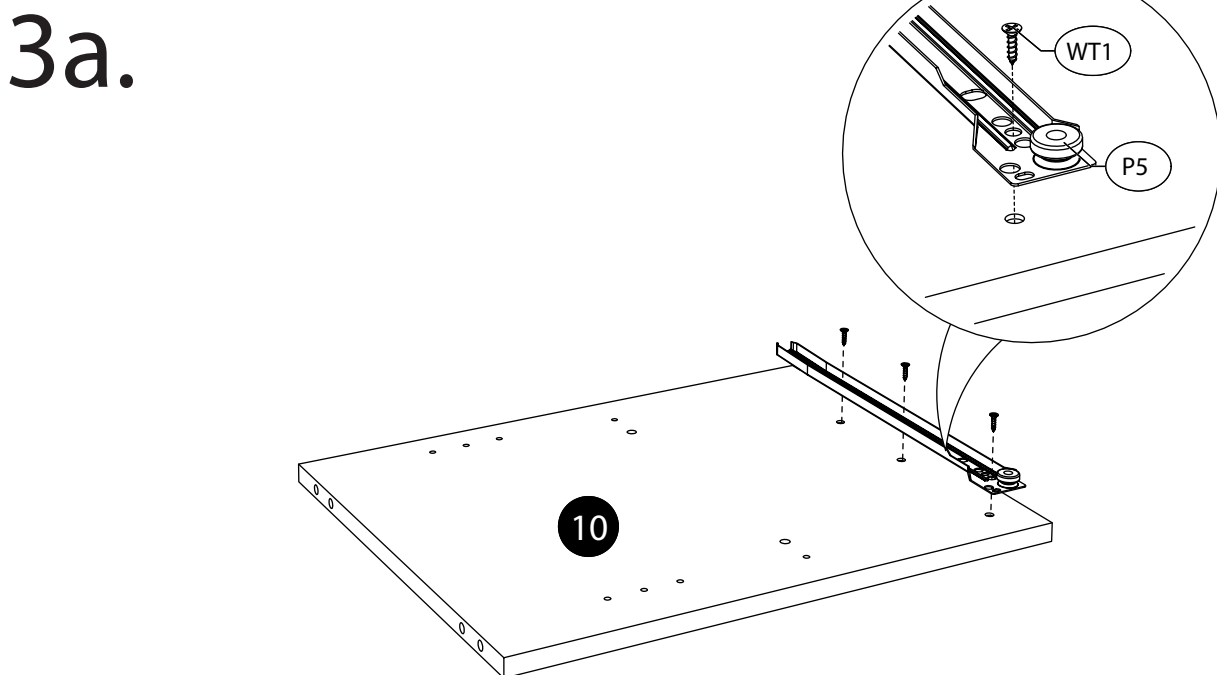
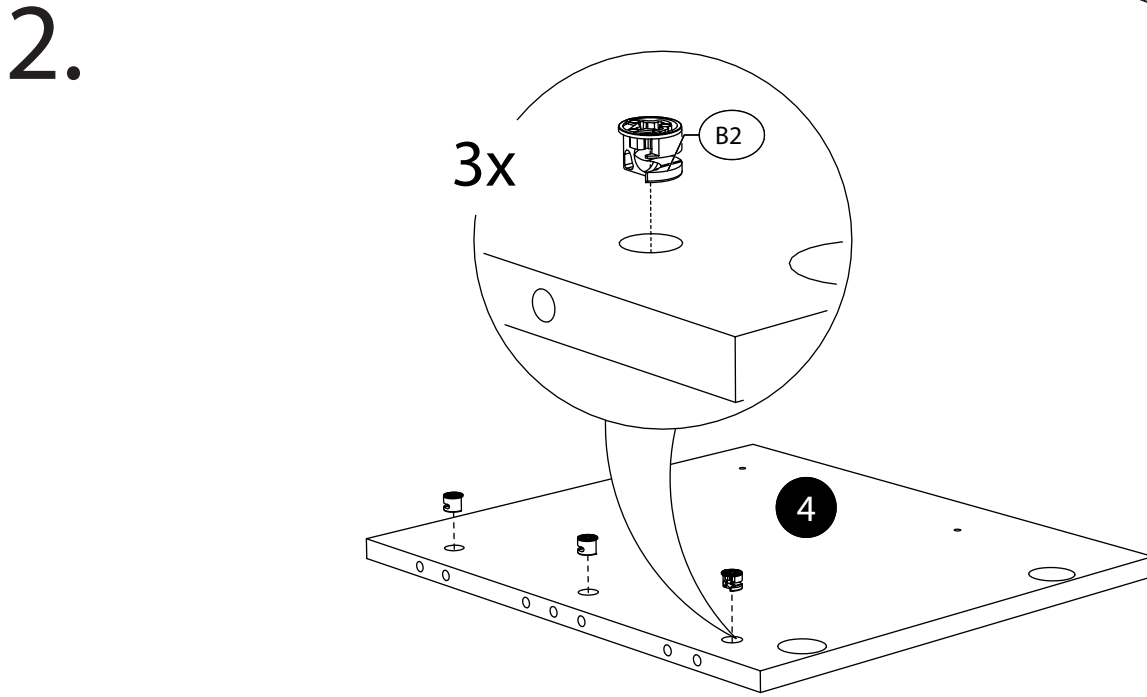
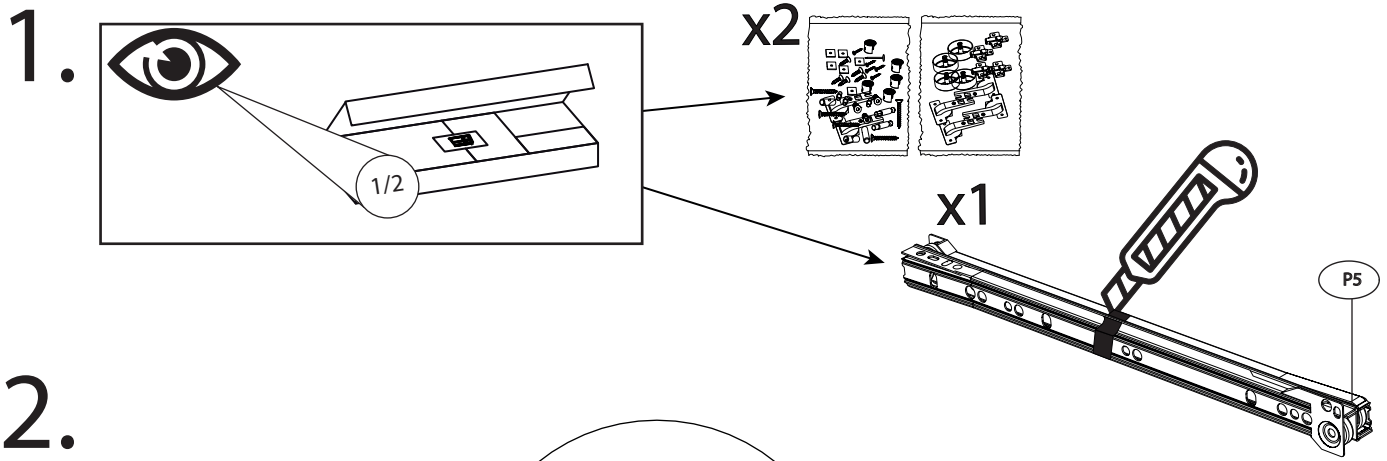

3b.

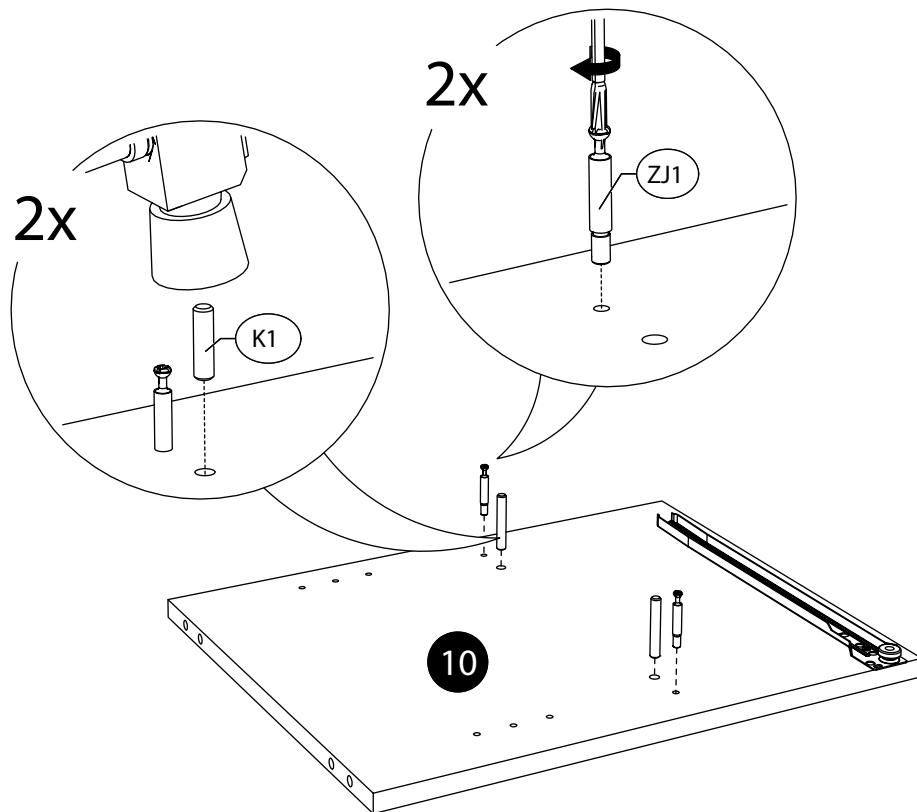

3c.

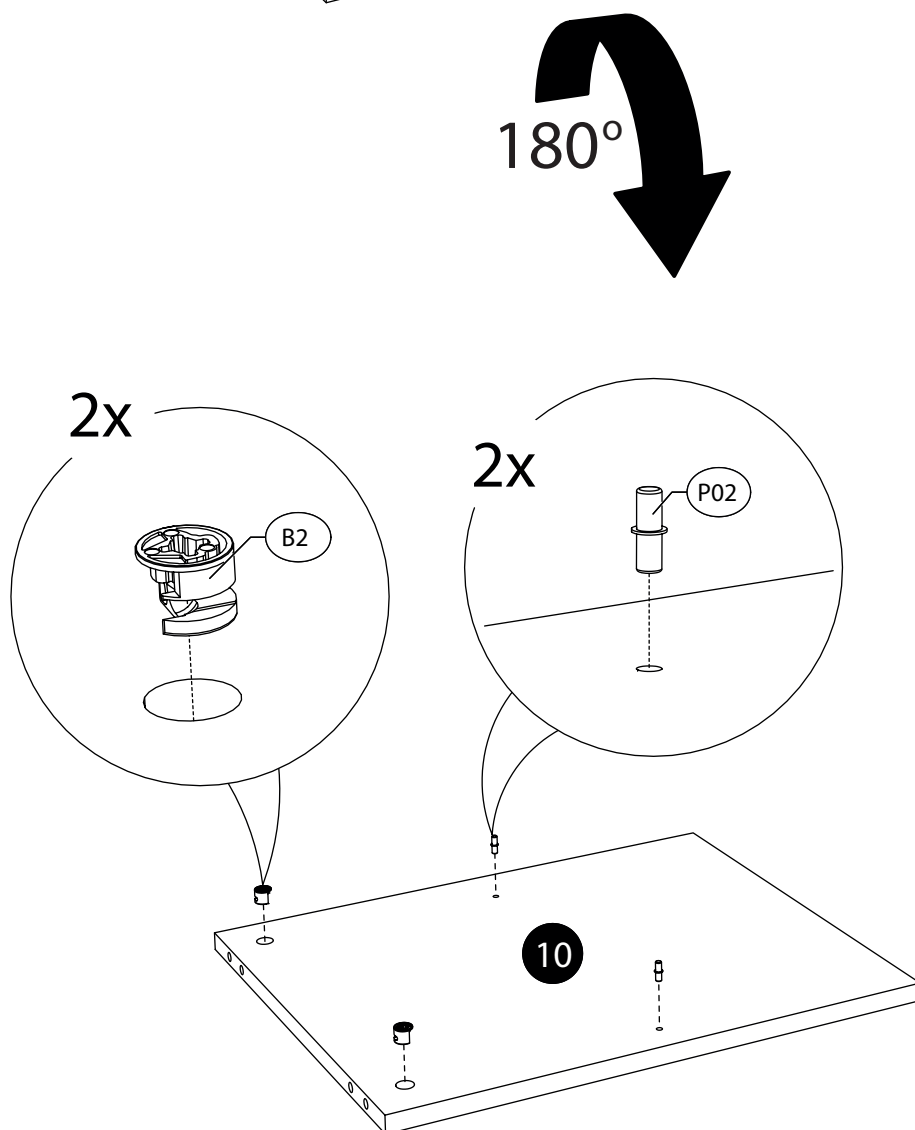

4a.

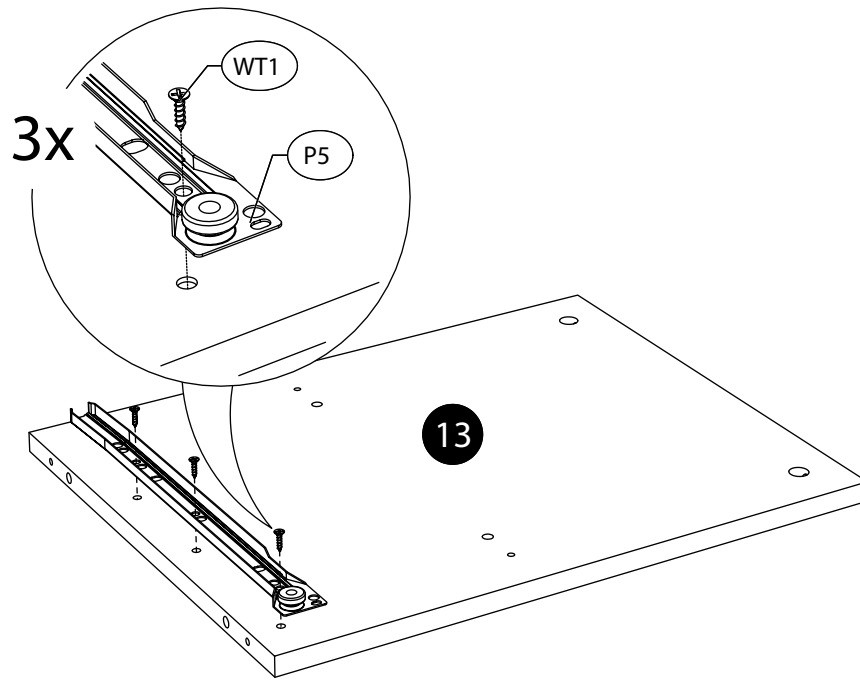

4b.

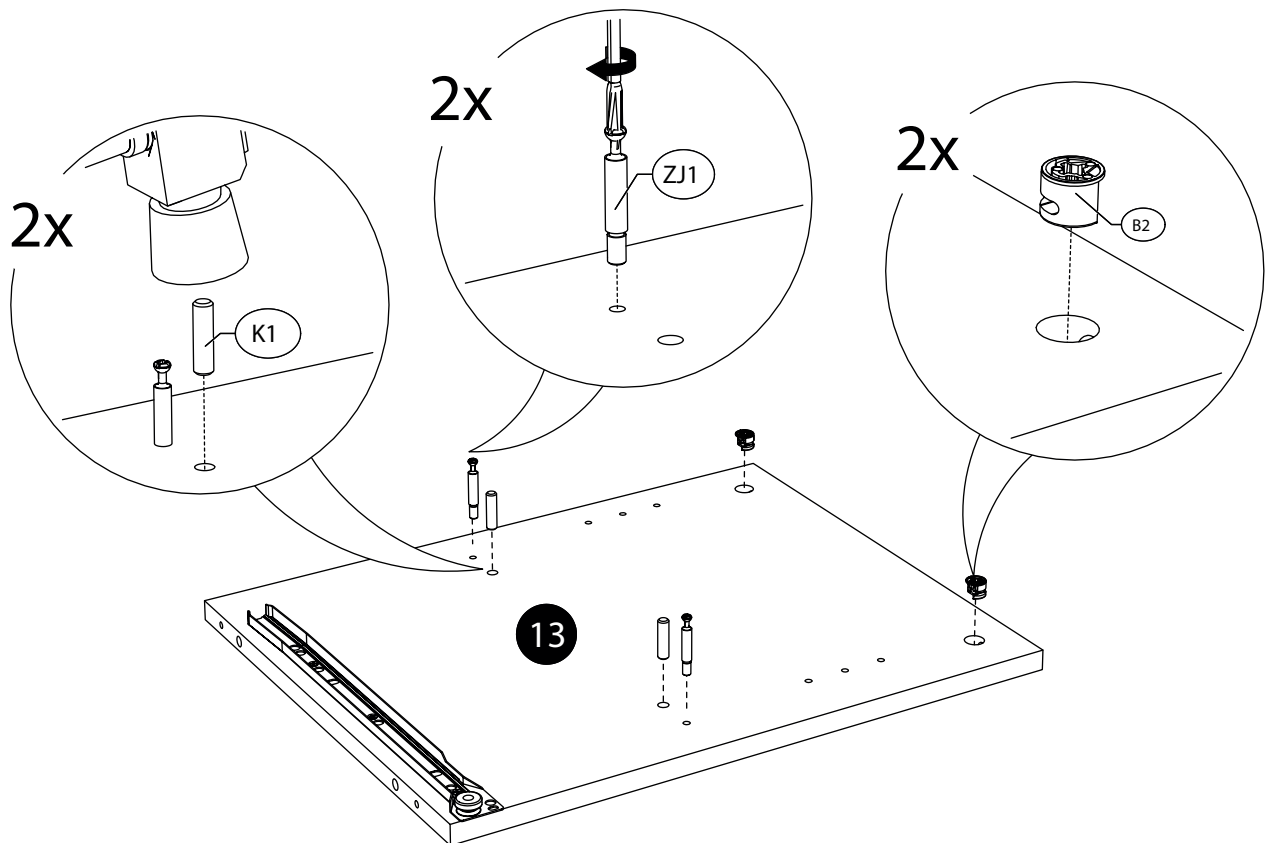

5a.

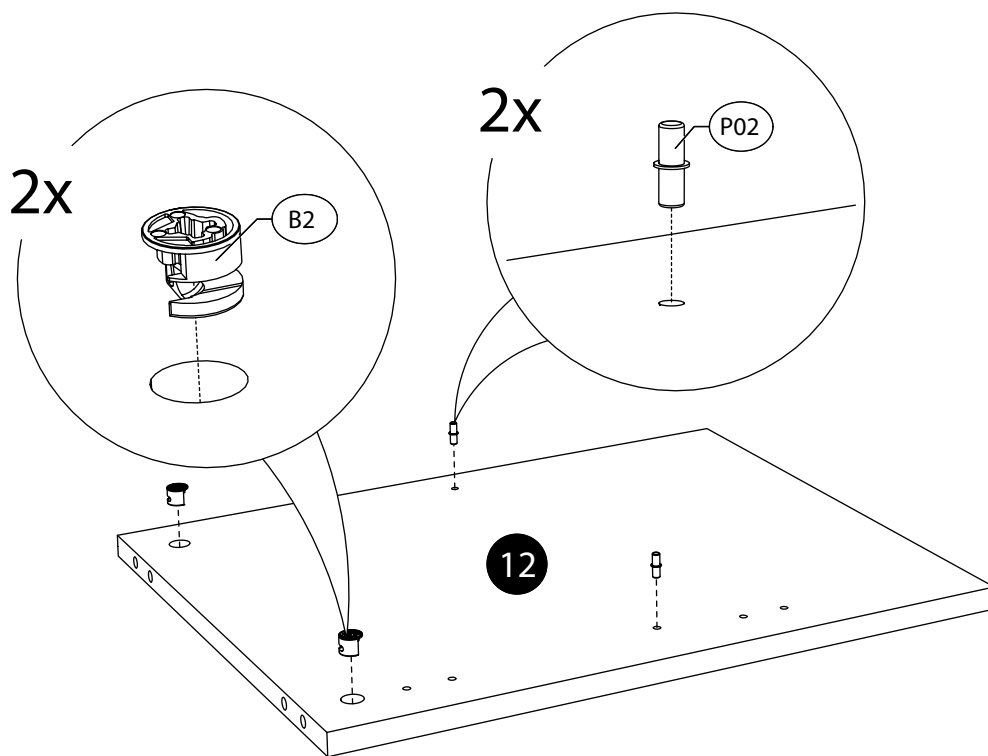

5b.

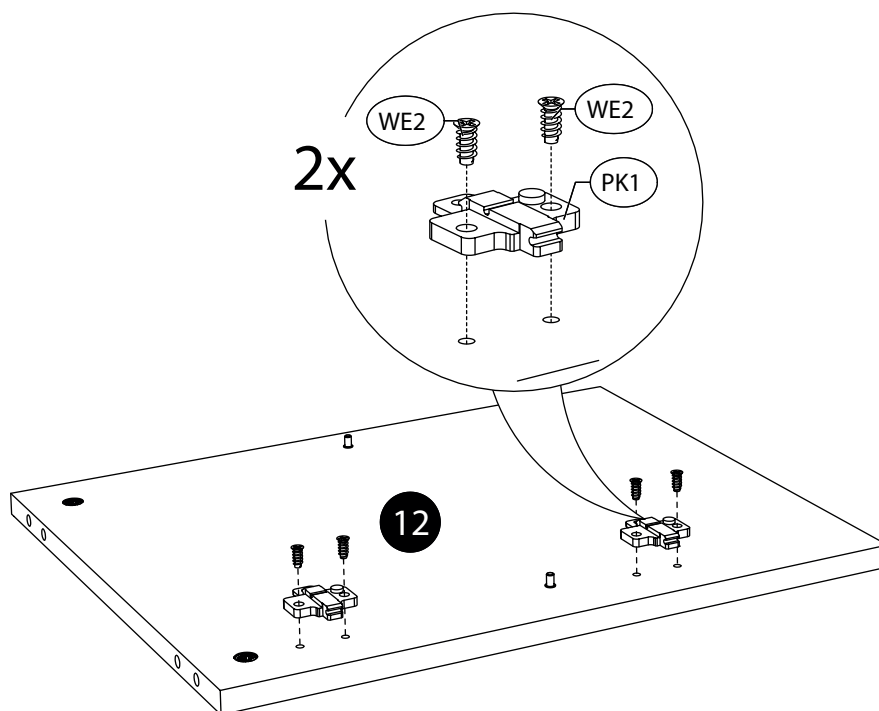

6.

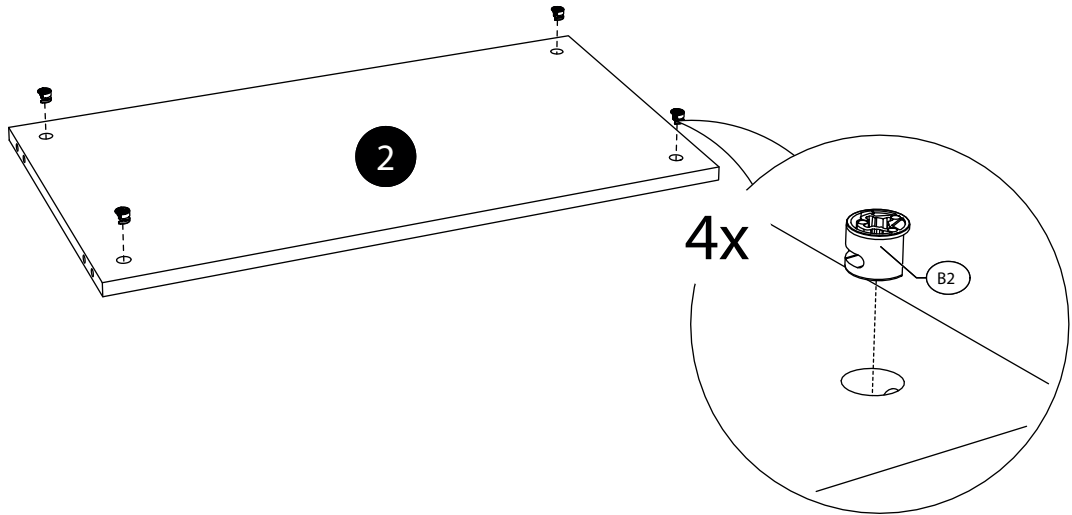

7.

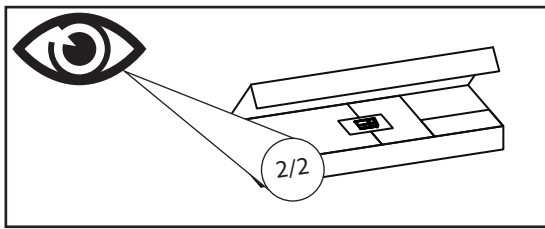

8.

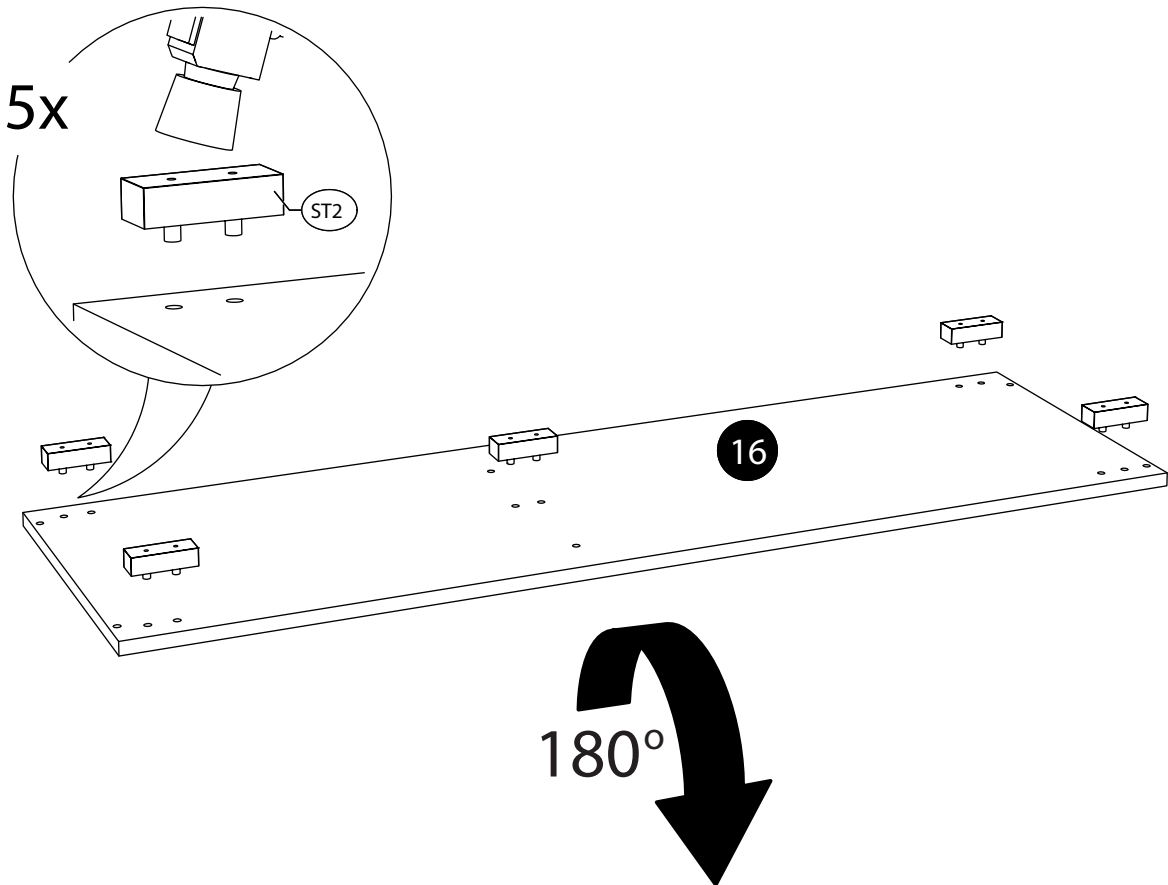

9.

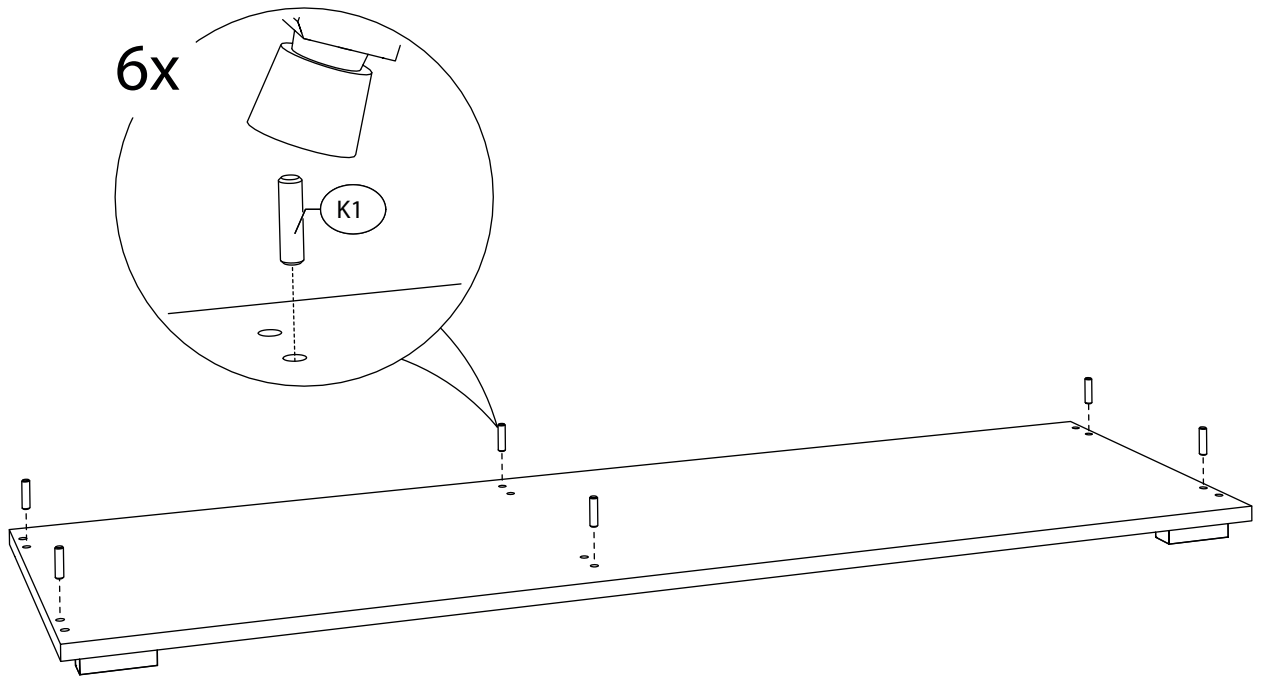

10.

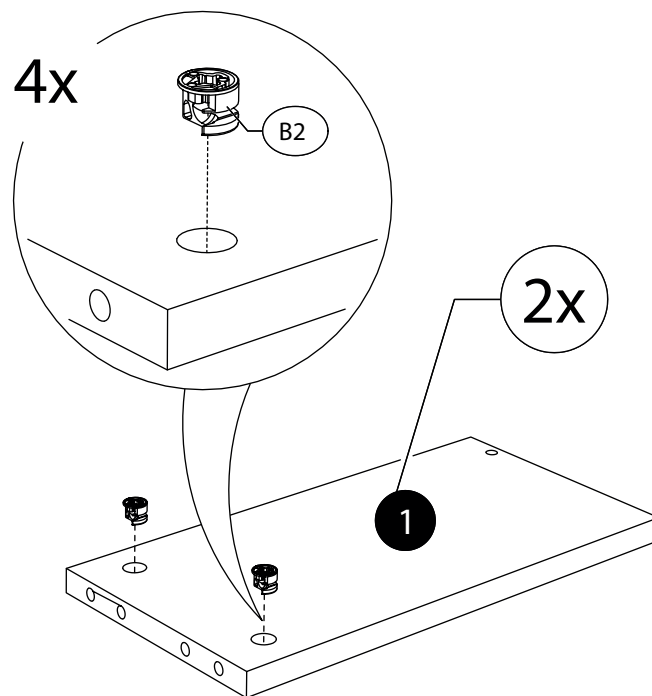

11a.

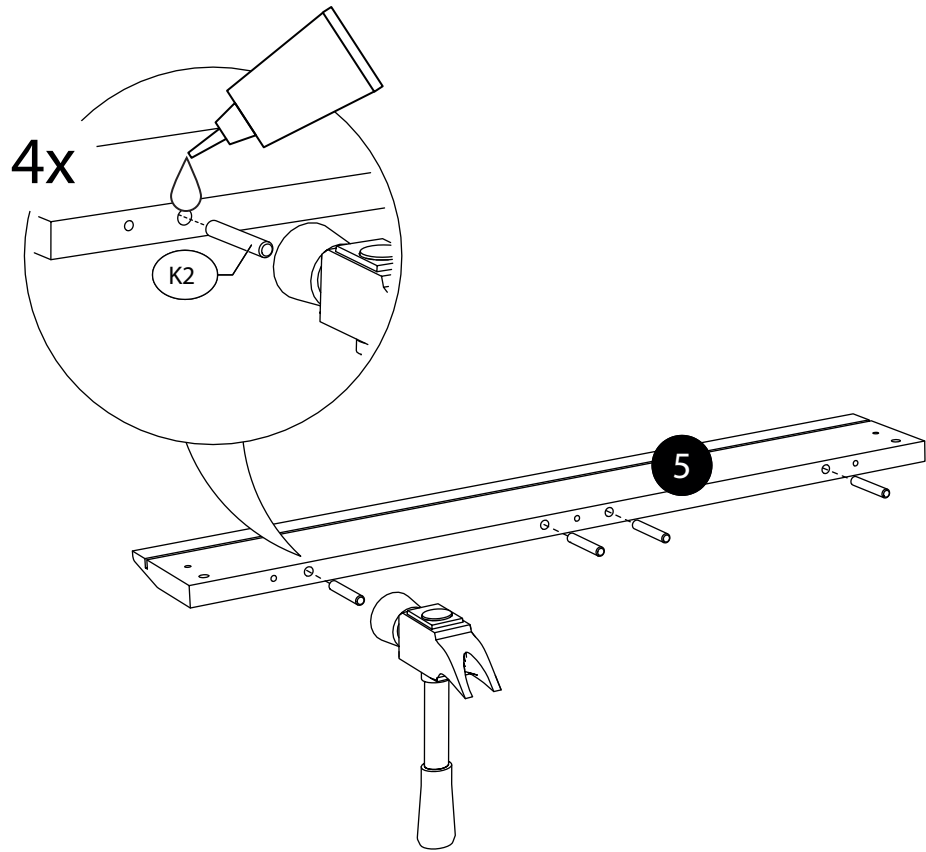

11b.

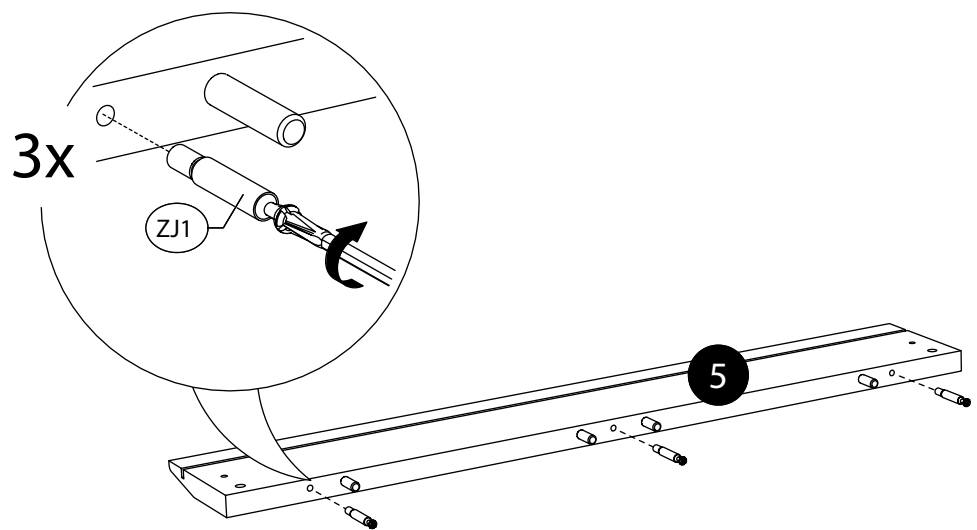

12.

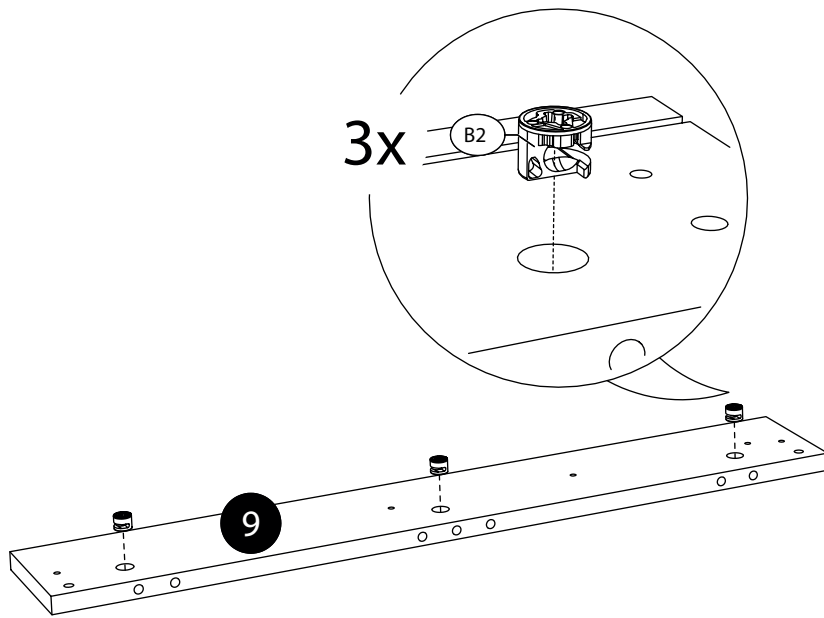

13.

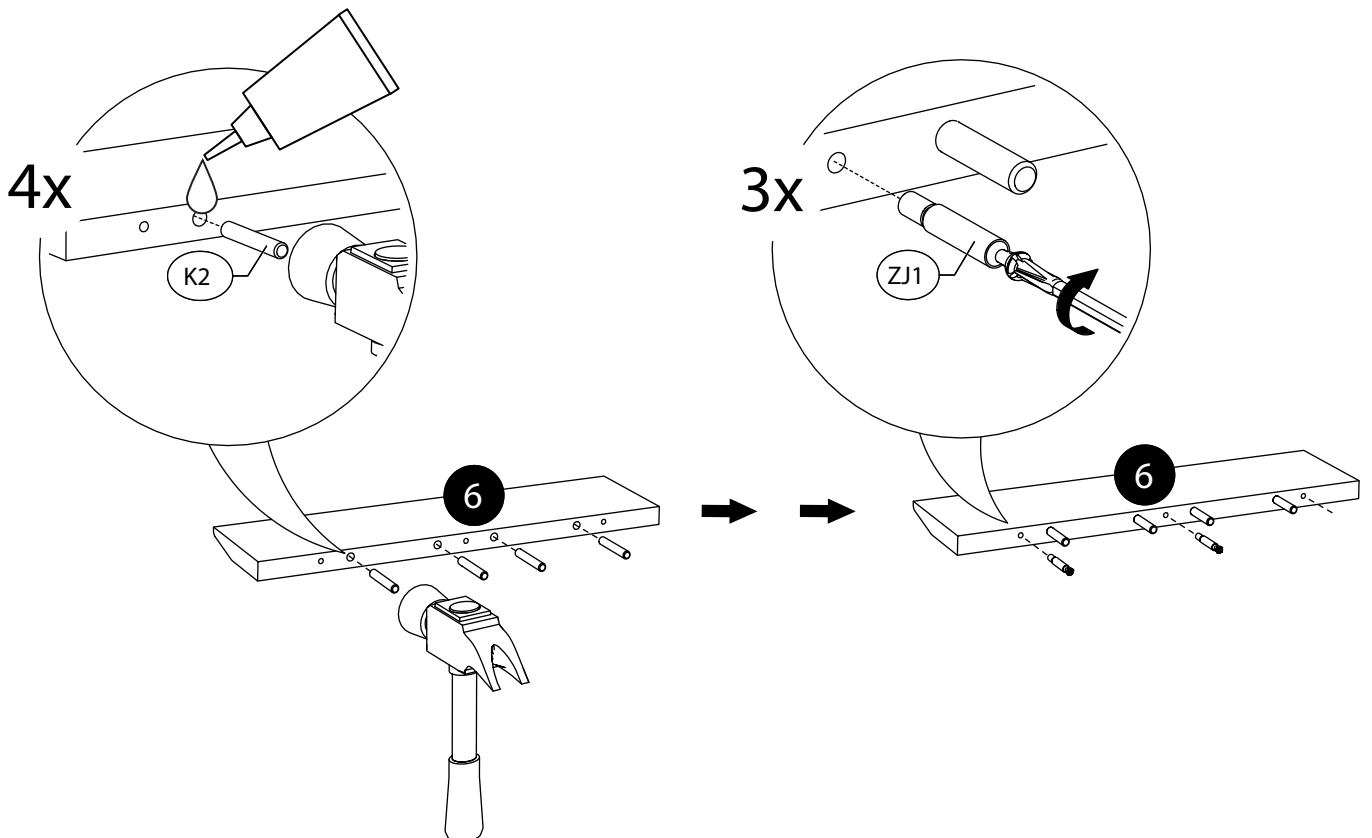

14.

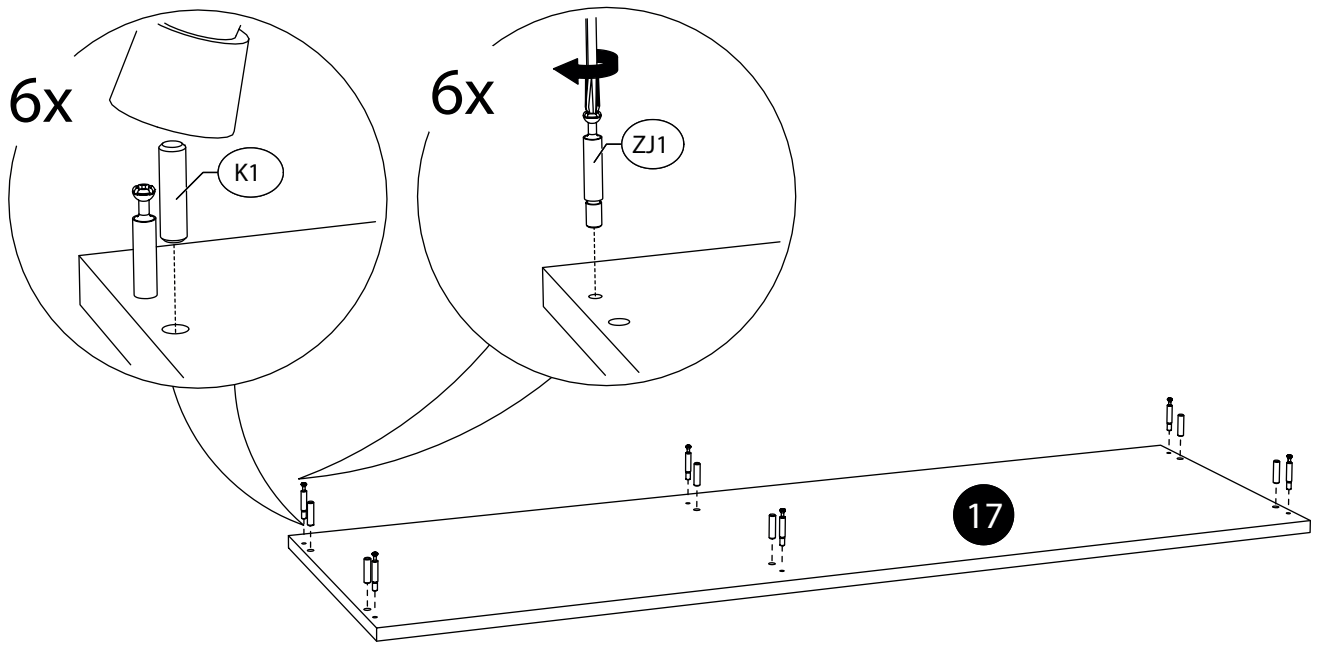

15.

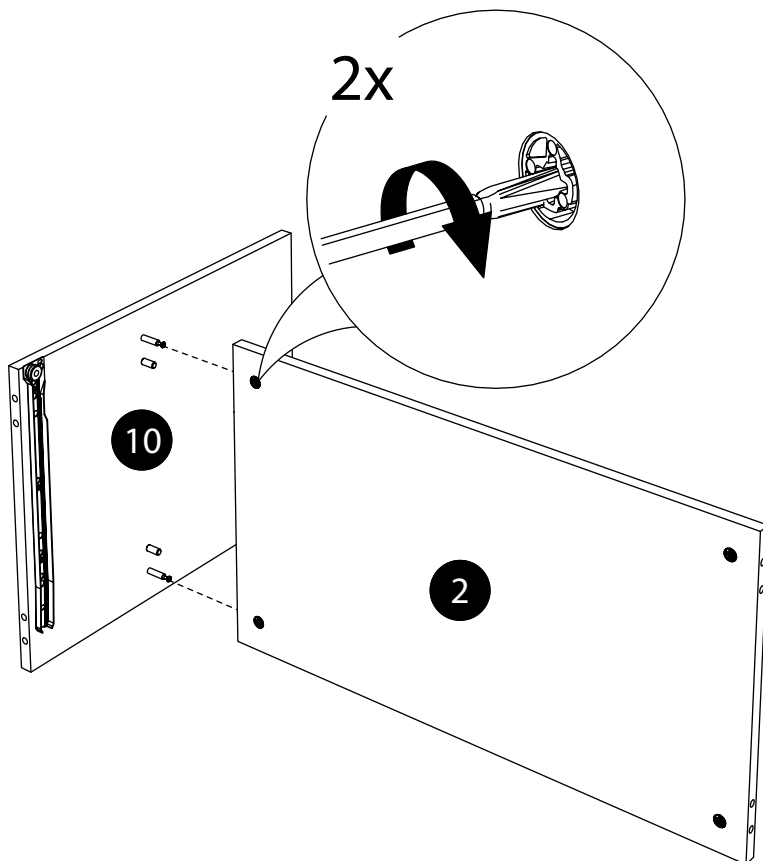

16.

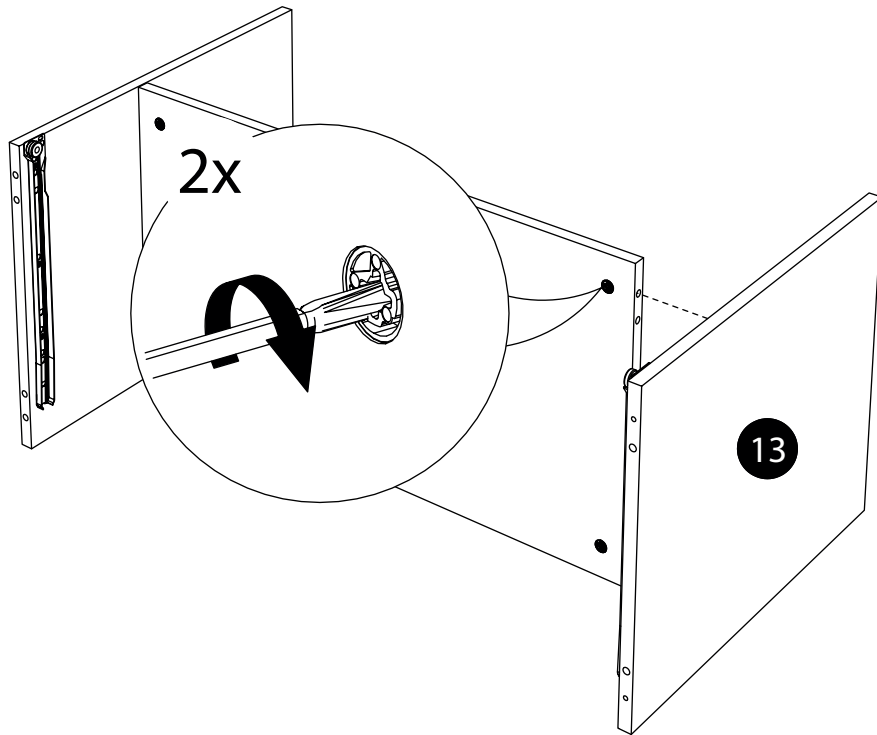

17.

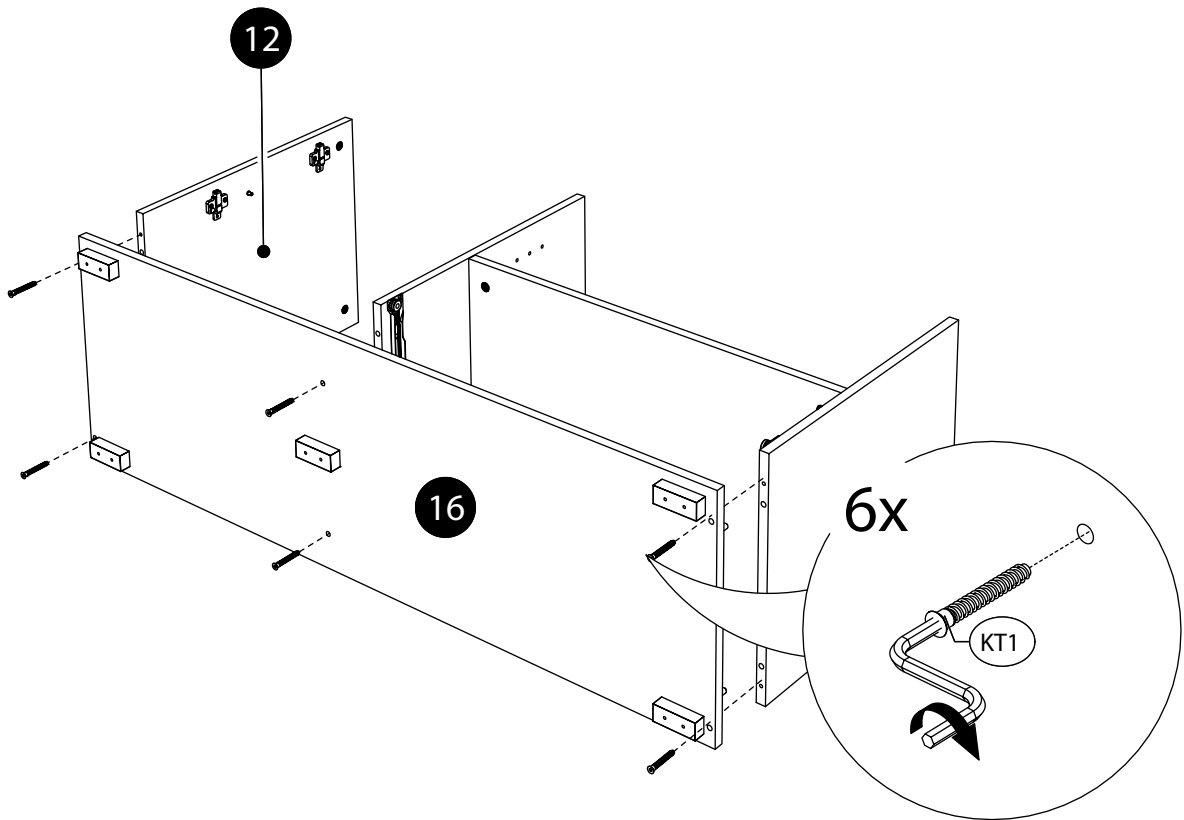

18.

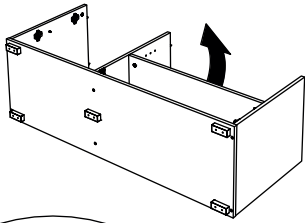

6x

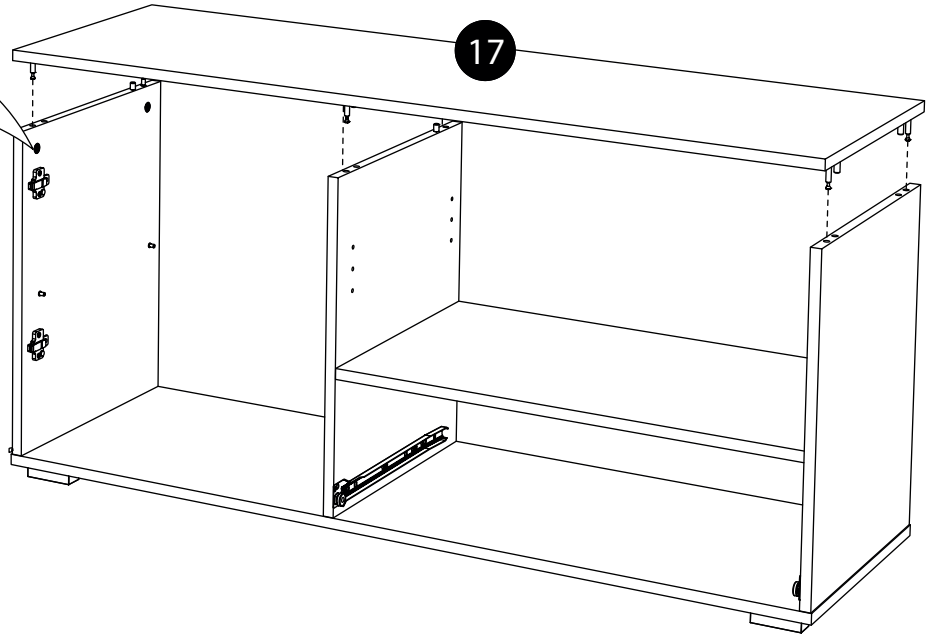
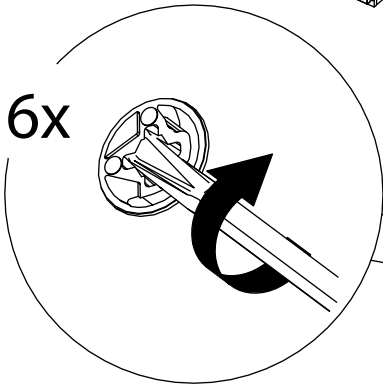

19.

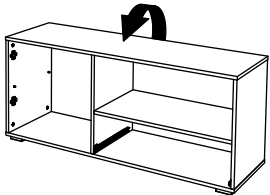

4x

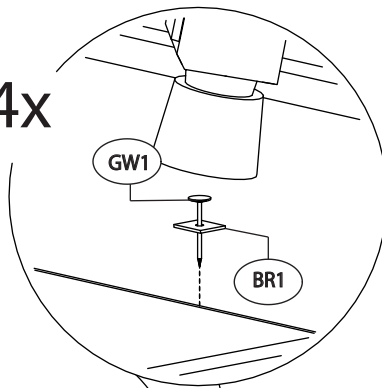

38

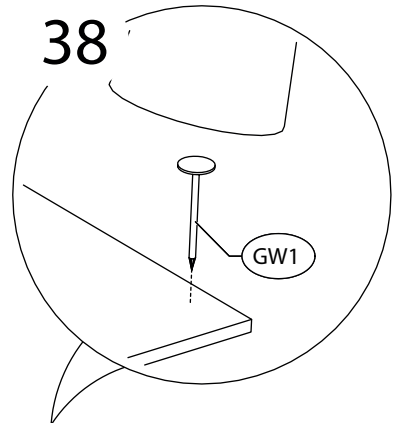

8

7

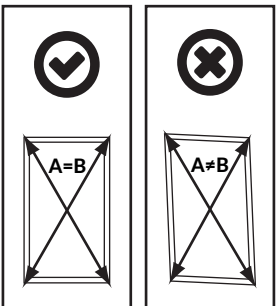
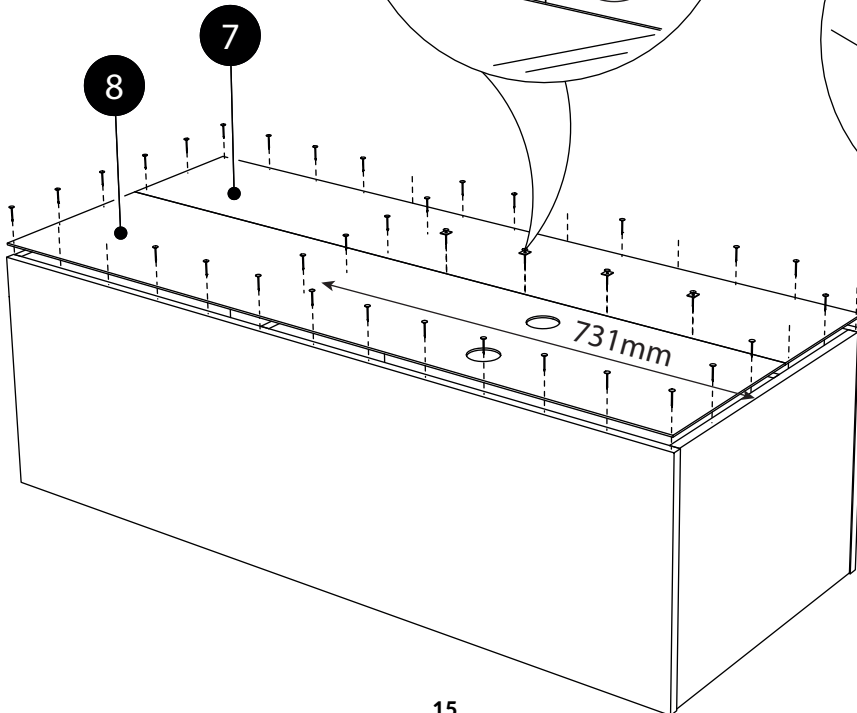

20.

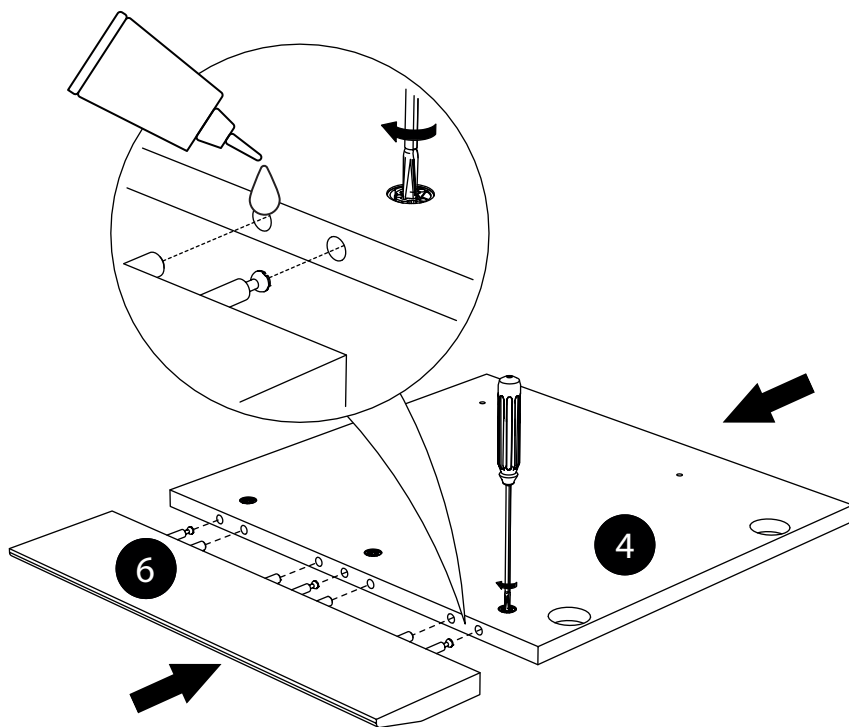

21.

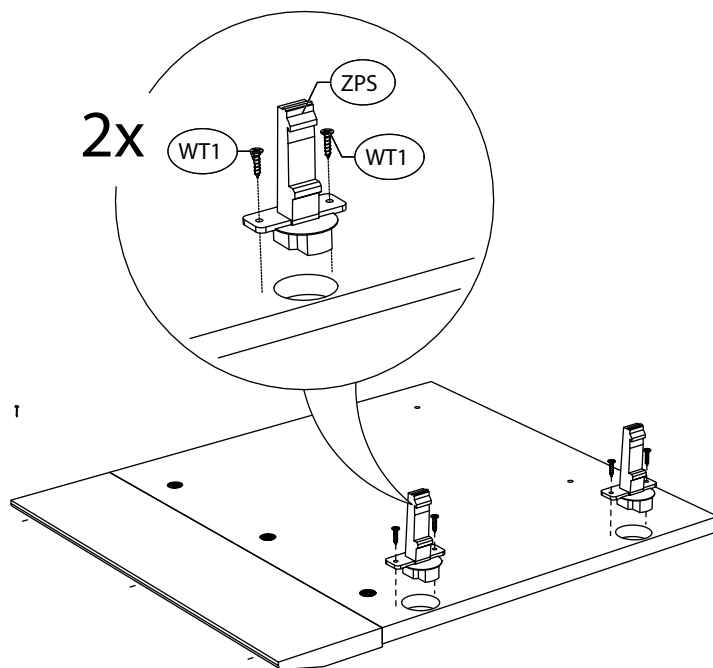

22.

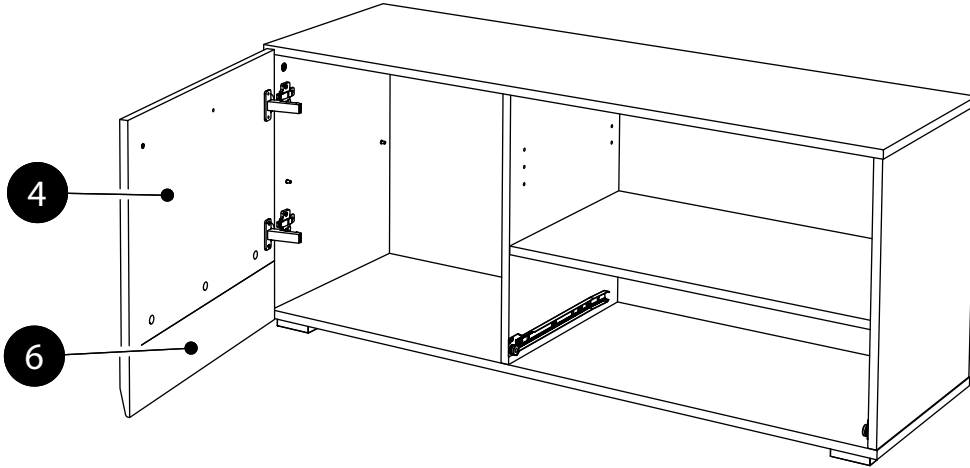
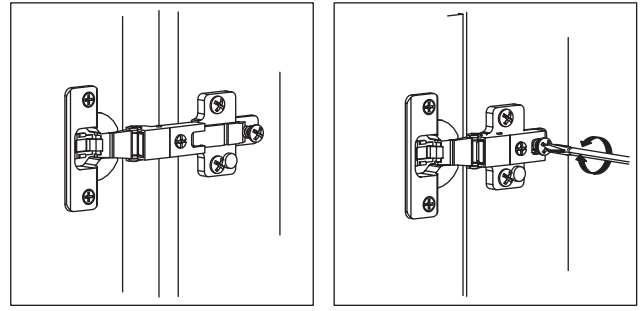
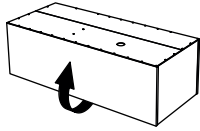

23.

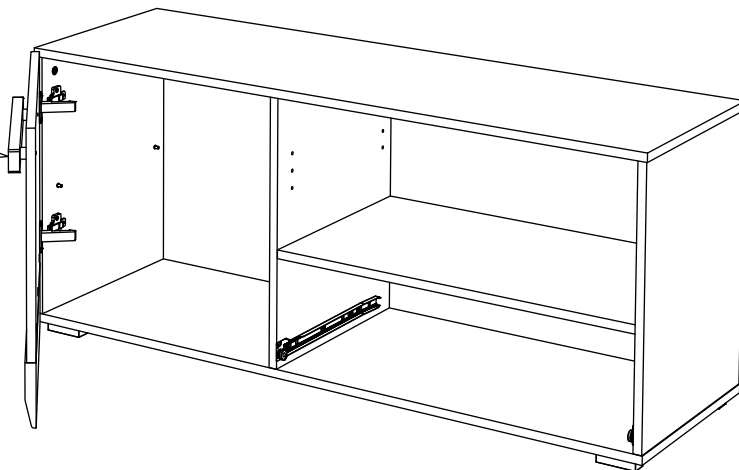
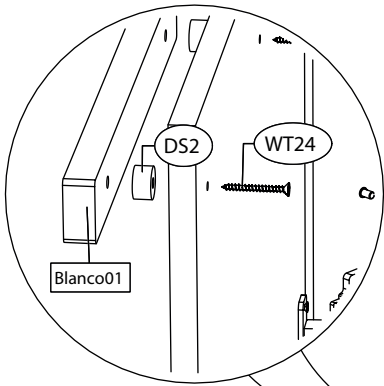

24.

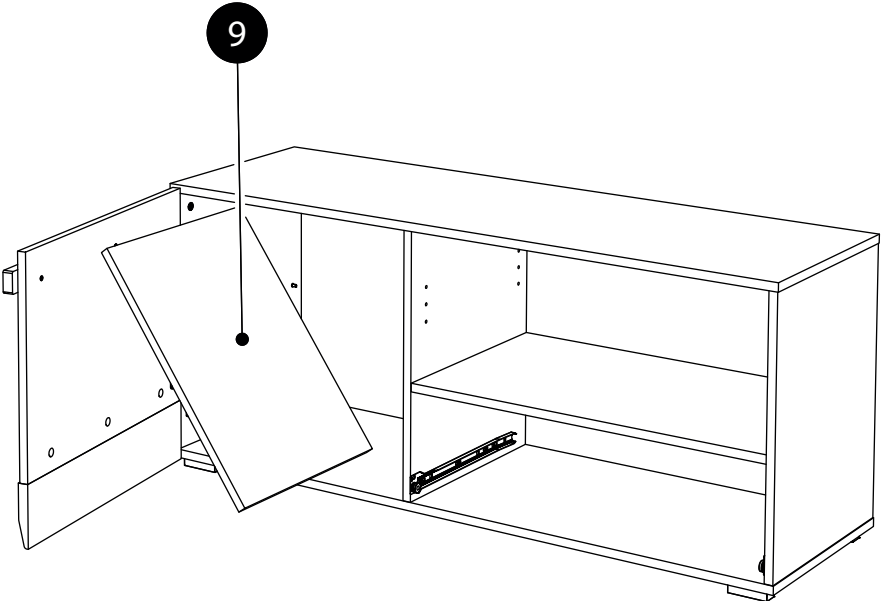

25.

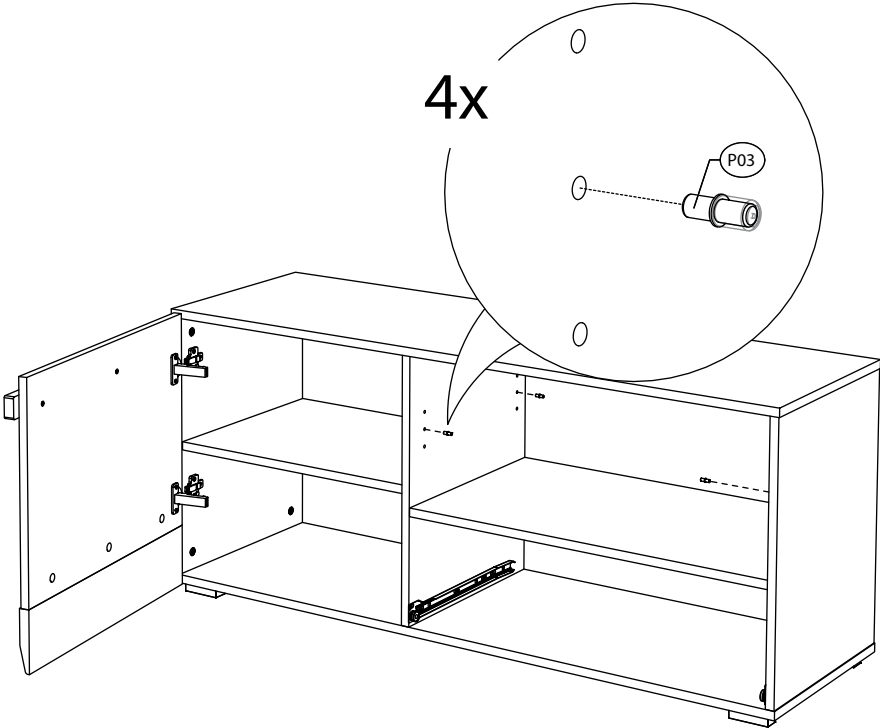

26.

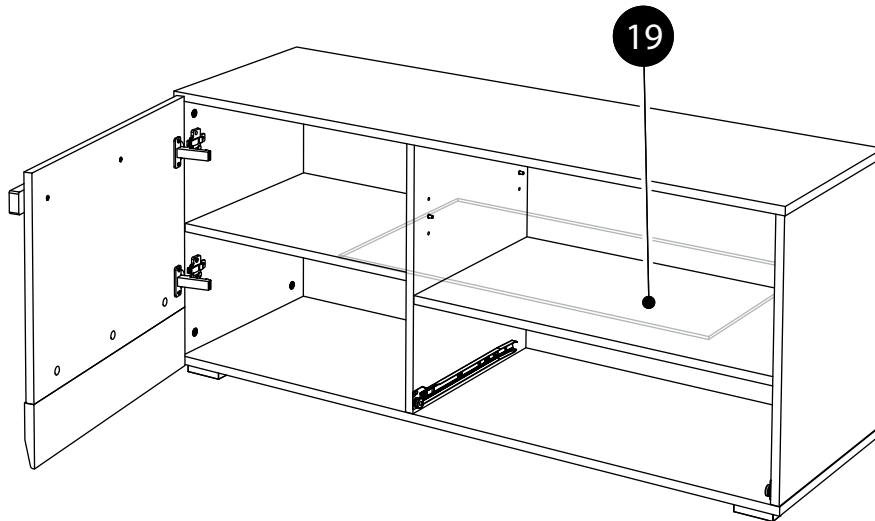

27.

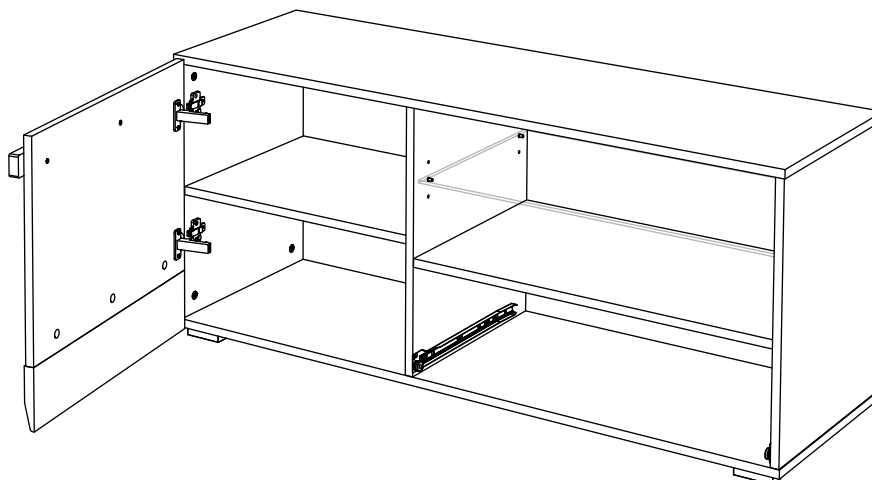
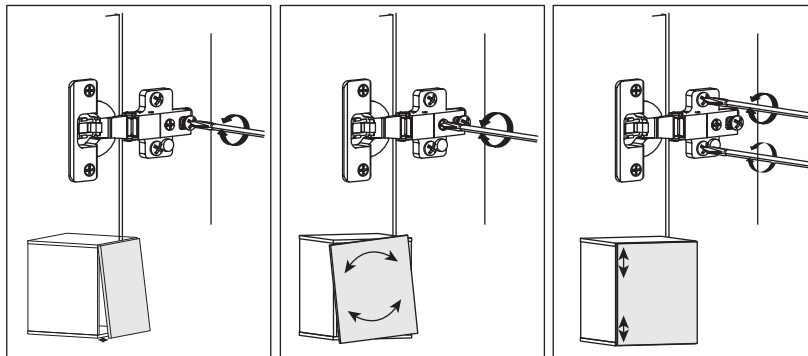

28.

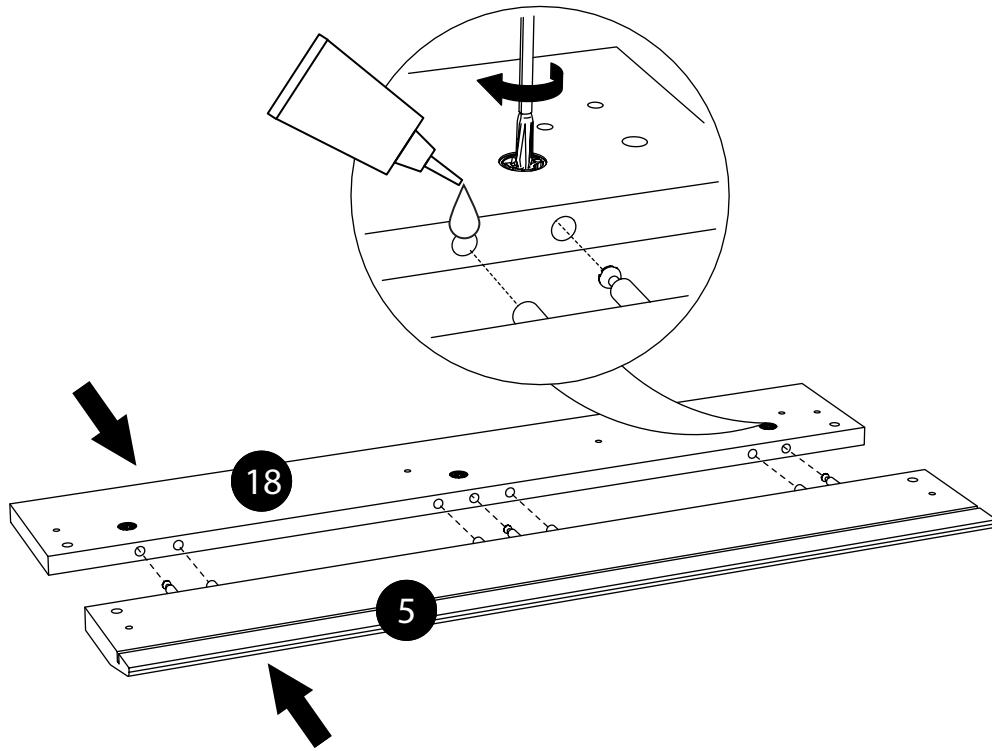

29.

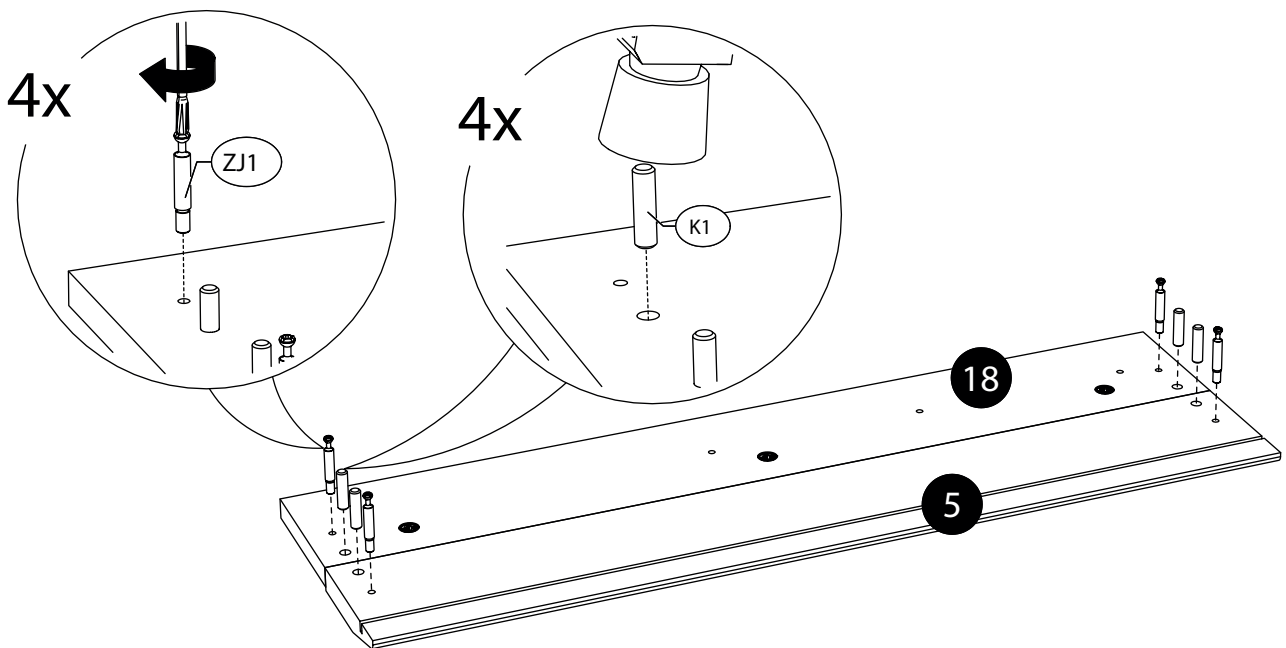

30.

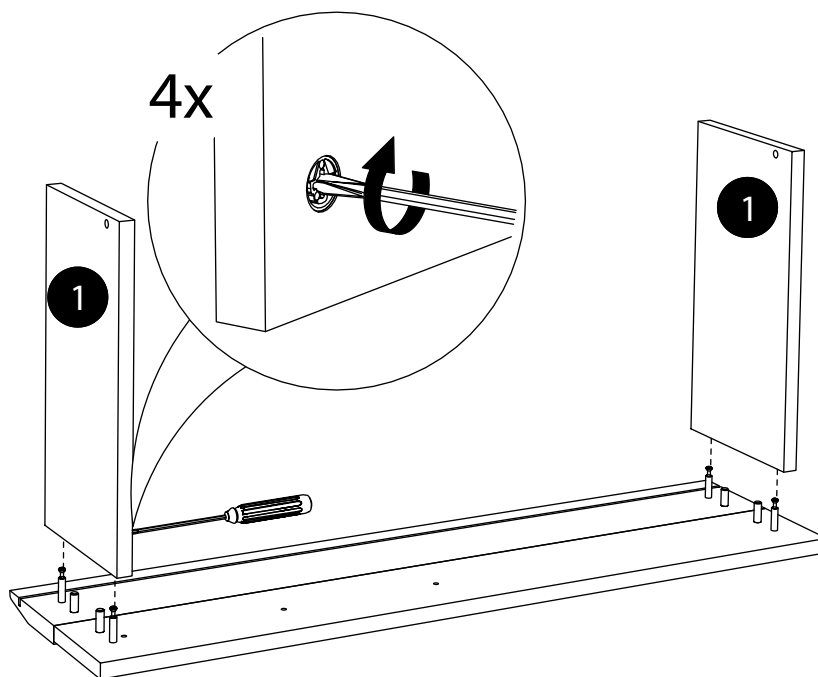

31.

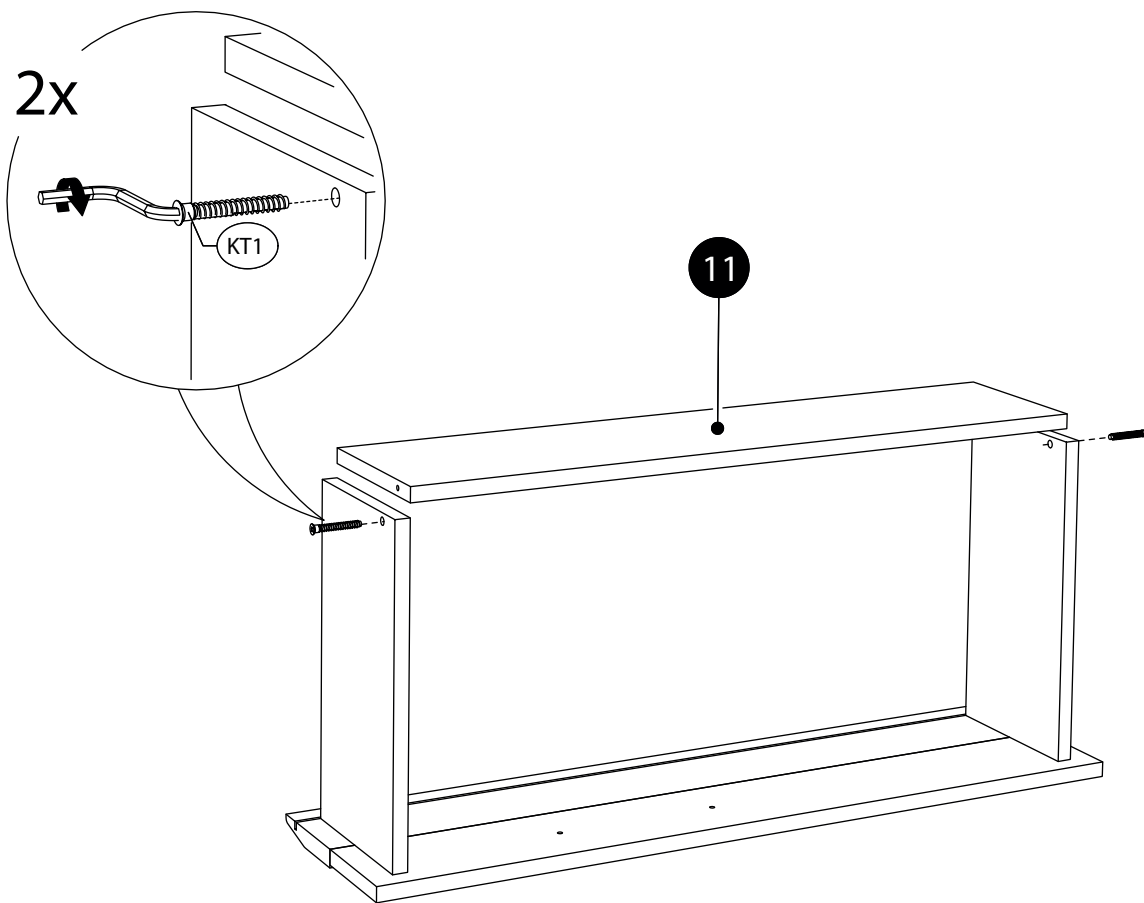

32.

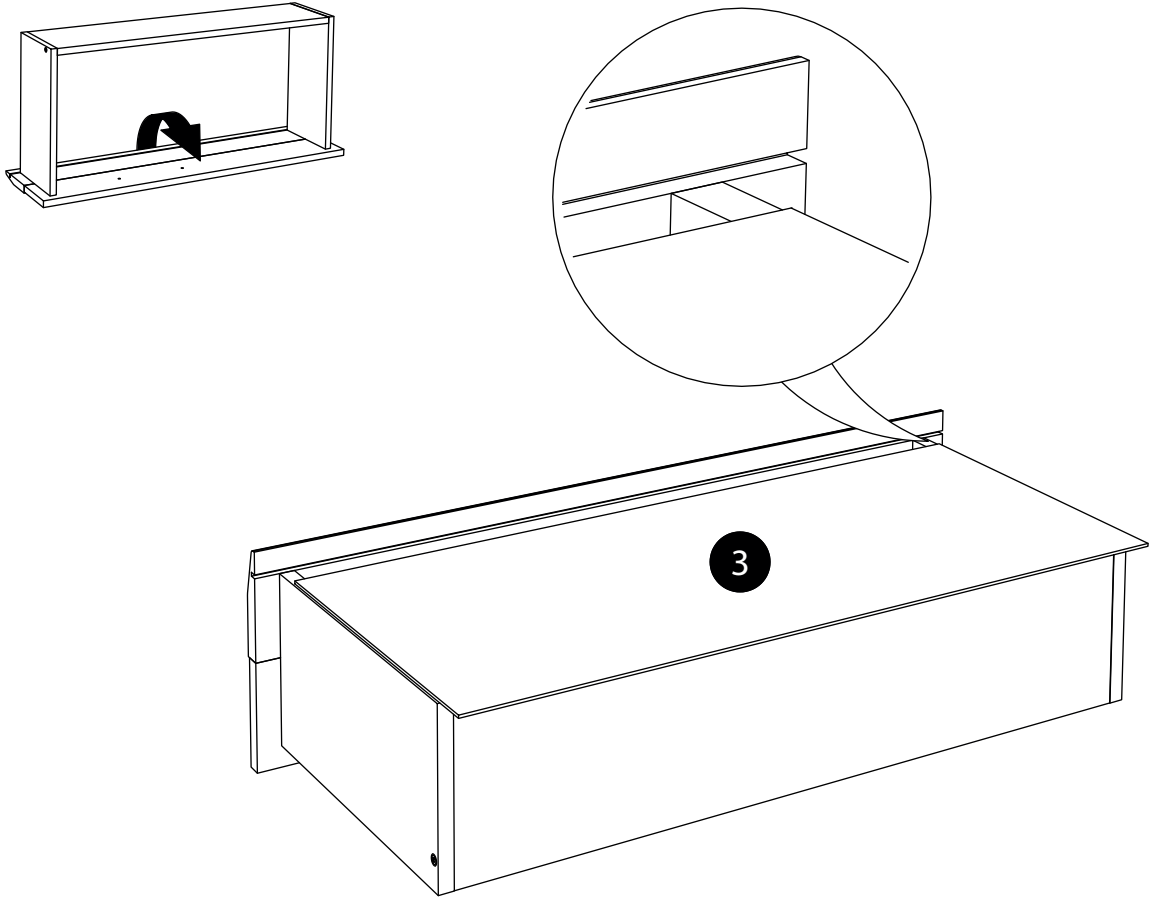

33.

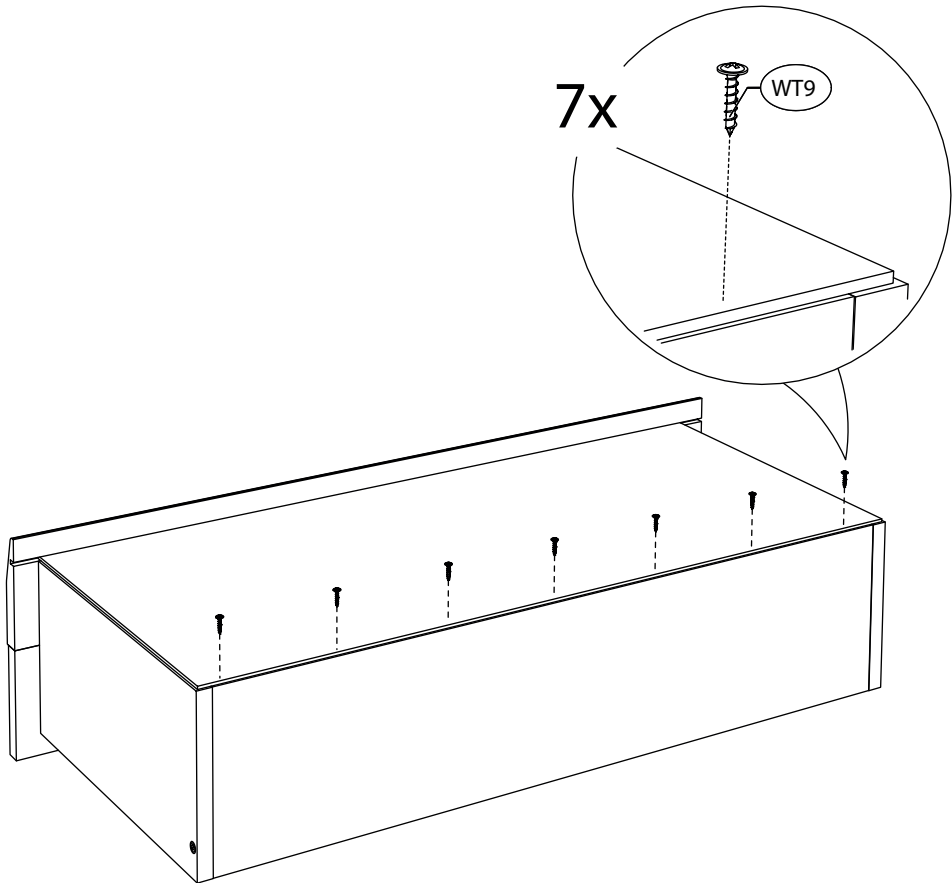

34.

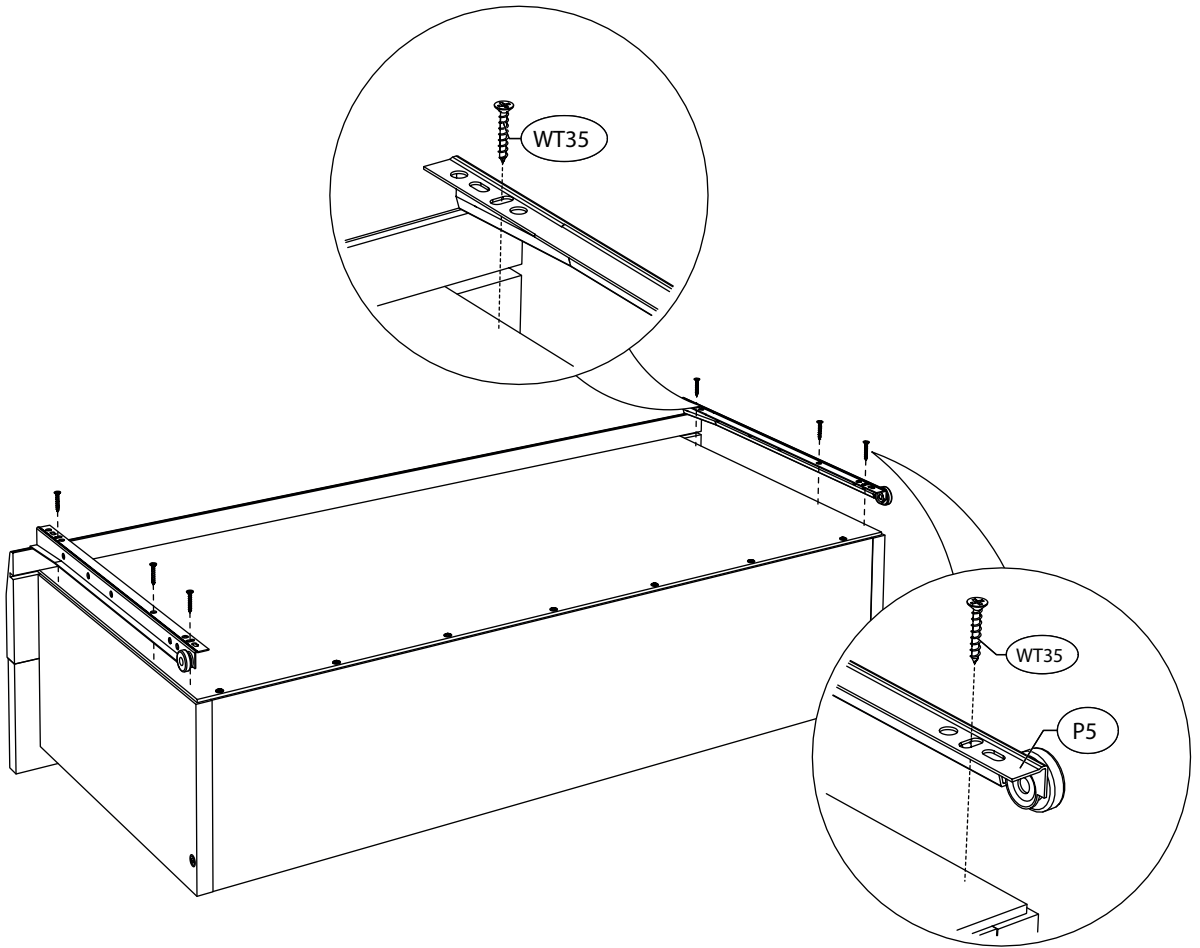

35.

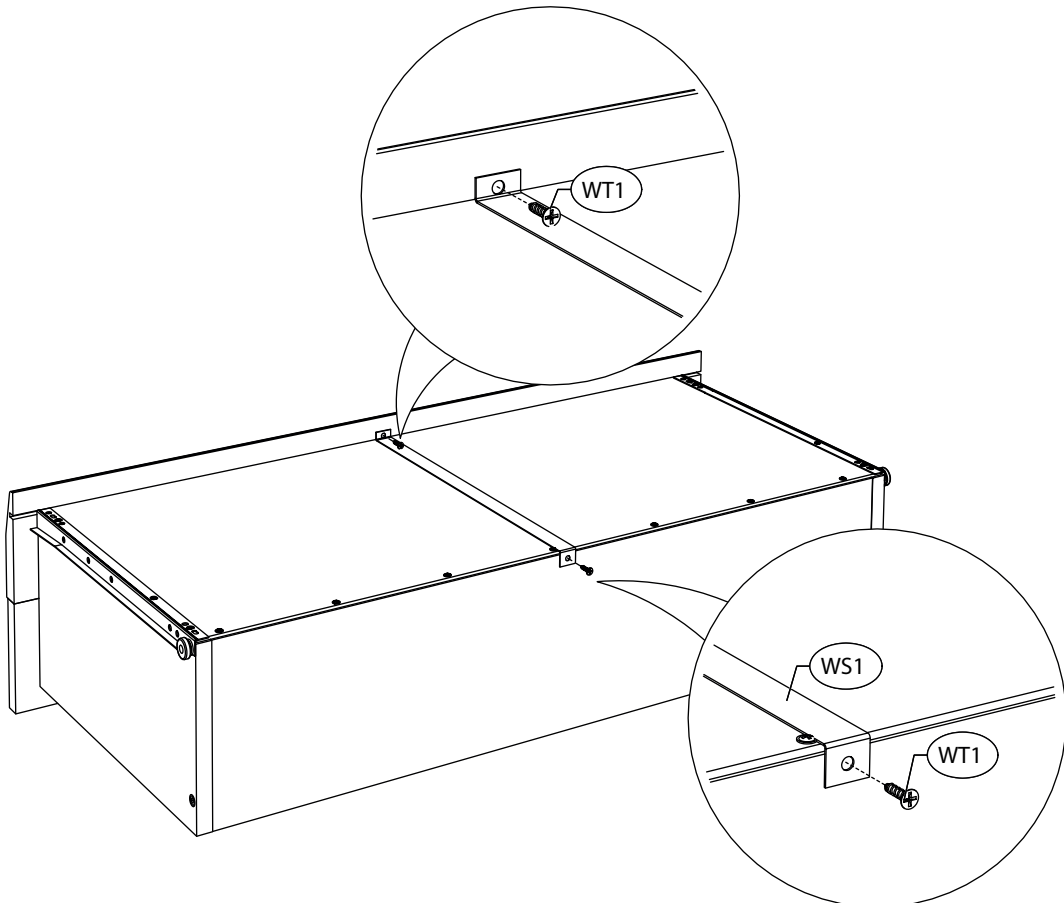

36.

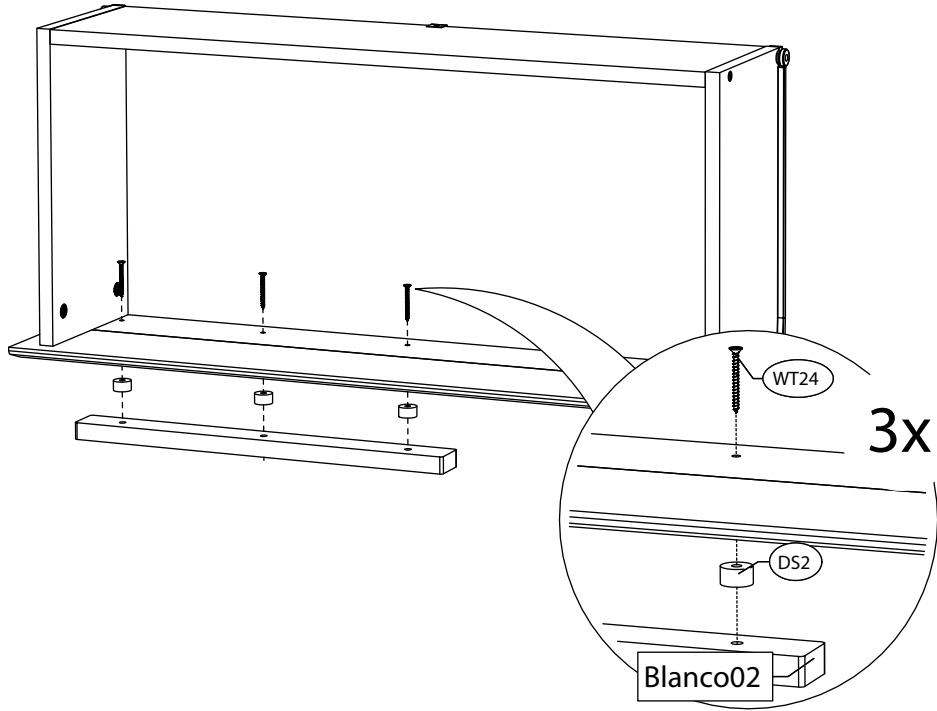
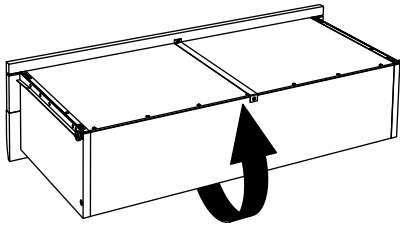

37.

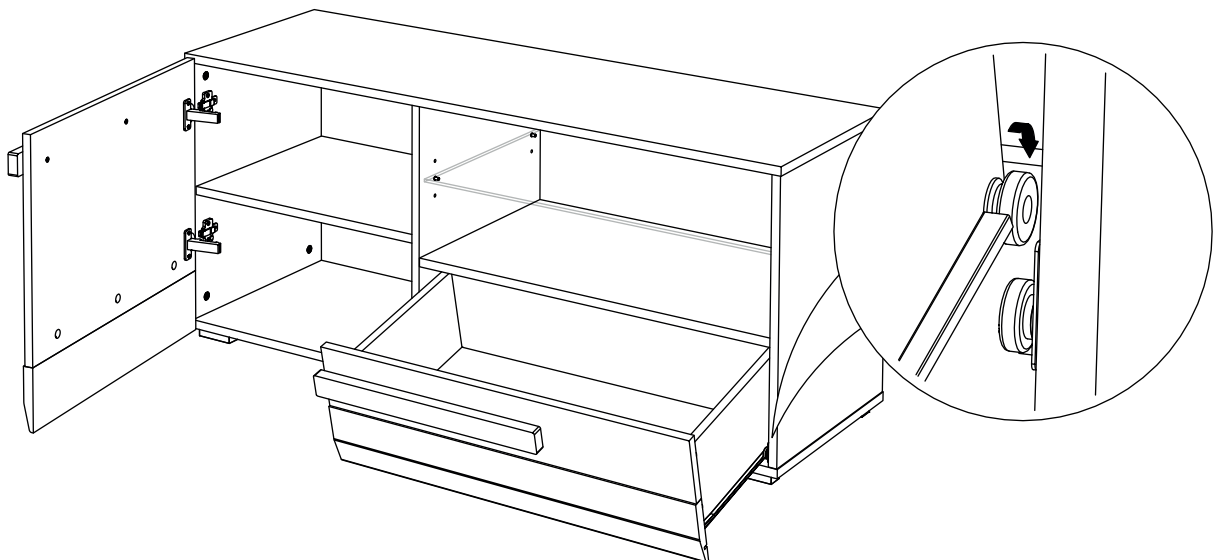

38.

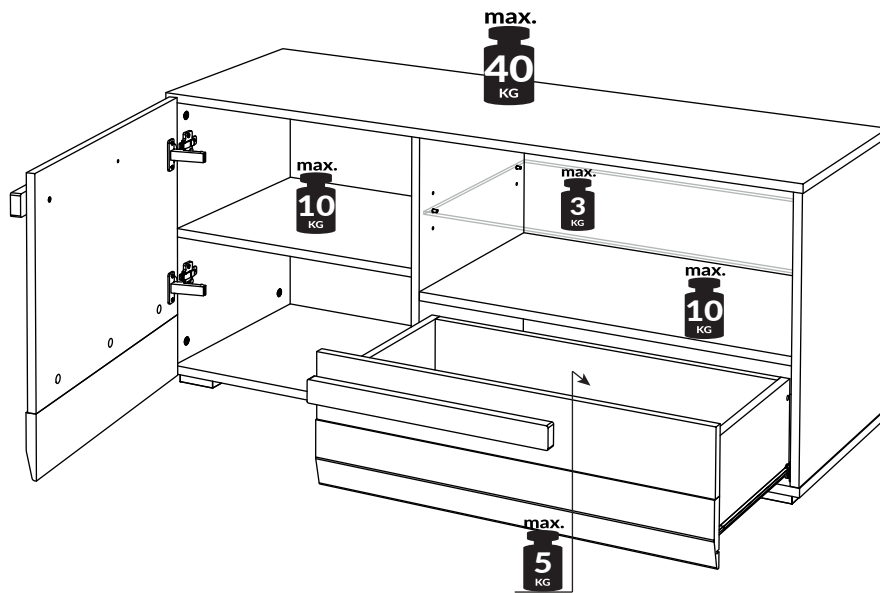

39.

