

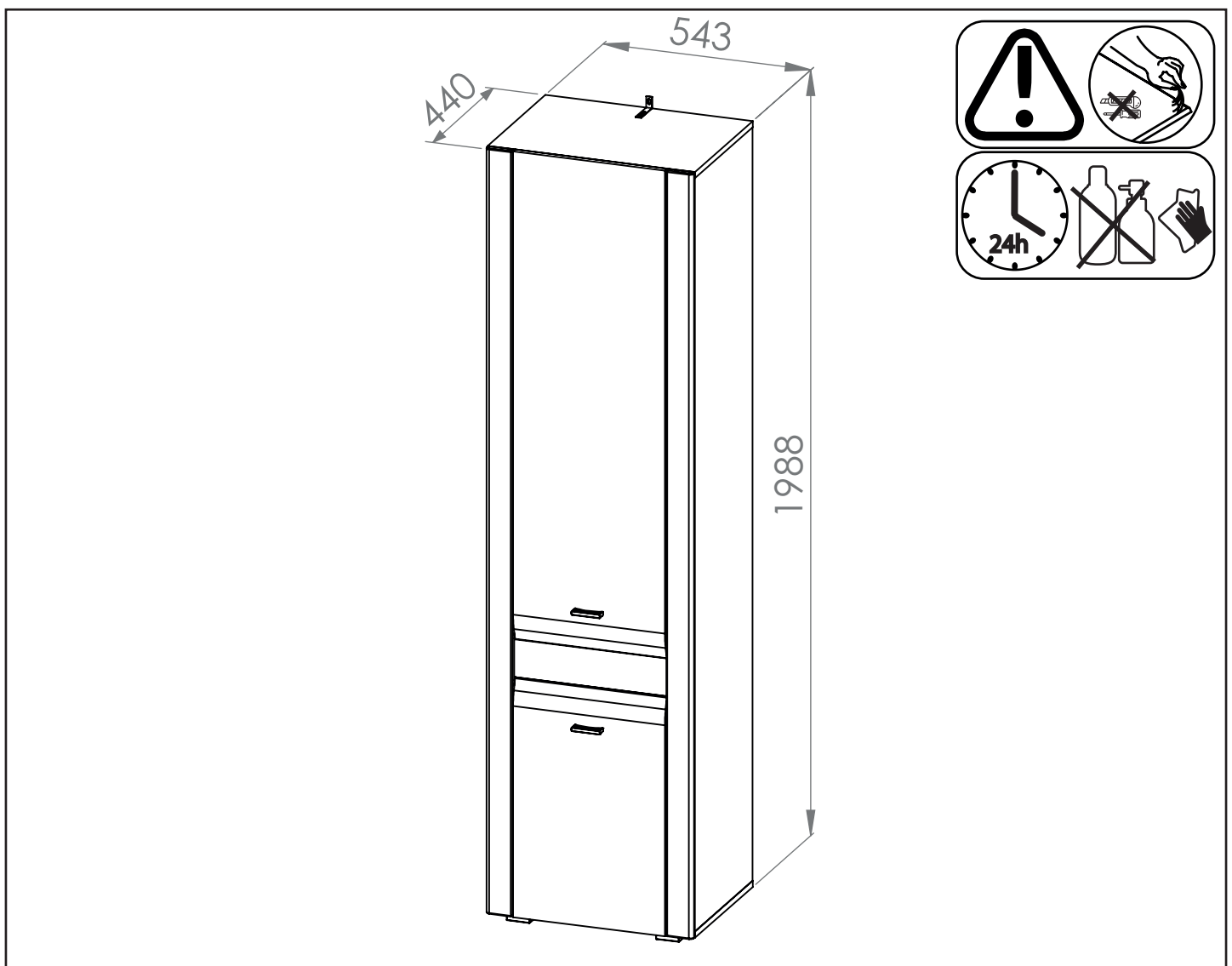

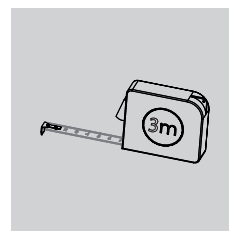
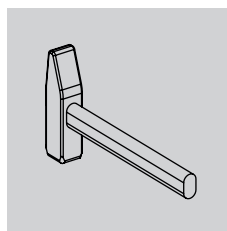
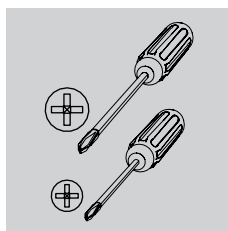
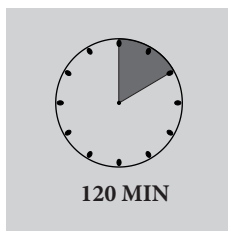

# ARKO 02

PL - Instrukcja montażu / BG - Сглобяване инструкция / CZ - Montáž instrukce / DE - Montageanleitung / EN - Assembling instruction / ES - Montaje de instrucciones / EST - Paigaldusjuhend / FR - Notice de montage / HR - Sastavljanje upute / HU - Szerelési utasítás / I - Istruzioni di montaggio / LT - Montavimo instrukcija / LV - Montāžas instrukcija / NL - Montage instructie / P - Montagem de instruções / RO - Asamblarea de instrucțiuni / RU - Сборка инструкция / S - Montering instruktion / SK - Montáž inštrukcie / SLO - Sestavljanje navodila / SRB - Склапање инструкцију / TR - Kurulum Talimatları / UKR - Збірка інструкція /

PL - Przed rozpoczęciem zapoznać się z instrukcją montażu / BG - Преди да започнете се отнасят към инструкциите за инсталиране / CZ - Před zahájením naleznete v montážním návodu / DE - Vor die montage, bitte beiliegende anweisungen folgen / EN - Before starting, refer to the assembling advice in annex / ES - Antes de començar referirse a las instrucciones de instalación / EST - Enne käivitamist vaadake paigaldusjuhiseid / FR - Avant de commencer, se reporter aux conseils de montage en annexe / HR - Prije početka pogledajte upute za instalaciju / HU - Megkezdése előtt olvassa el a telepítési utasításokat / I - Avanti di cominciare, riportate agli consigli di montaggio / LT - Prieš pradant kreiptis į montavimo instrukcija / LV - Pirms sākt montāžu, iepazīties ar instrukciju / NL - Voordat u begint Zie de installatie-instructies / P - Antes de começar a consultar as instruções de instalação / RO - Înainte de a începe să consultați instrucțiunile de instalare / RU - Перед началом обратитесь к инструкции по установке / S - Innan du börjar se Installationsanvisningen / SK - Pred začatím nájdete v montážnom návode / SLO - Pred začetkom glejte navodila za namestitev / SRB - Пре почетка погледајте упутства за инсталацију / TR - Kurulumla başl madan önce, montaj talimatnamesini sirisiyla takip edin. / UKR - Перед початком зверніться до інструкції з установки /

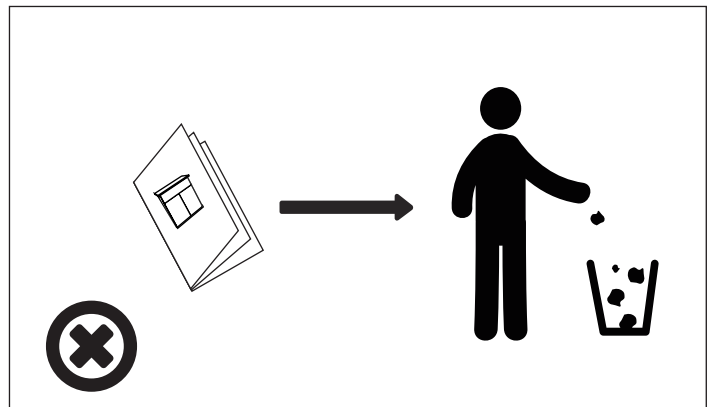
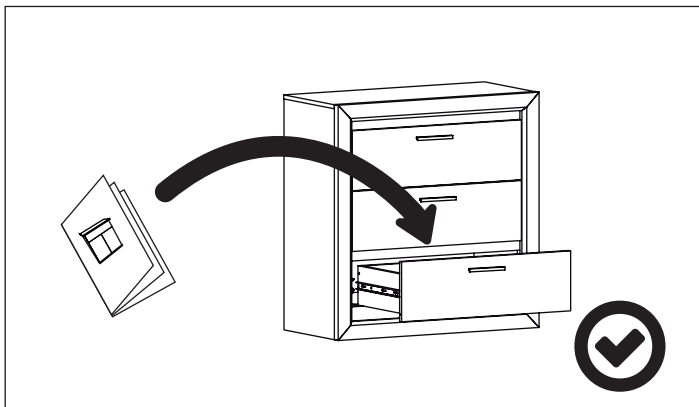
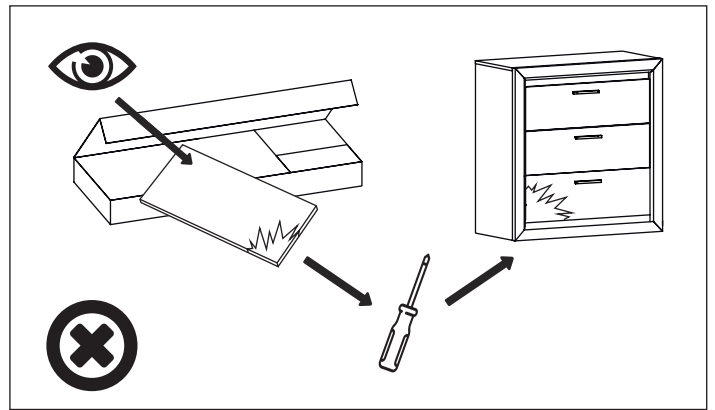
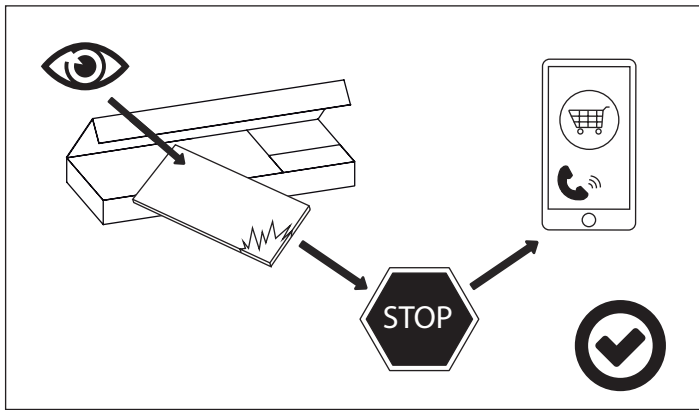
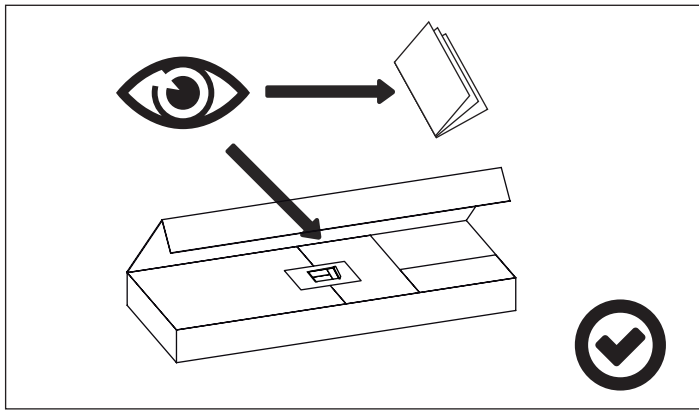







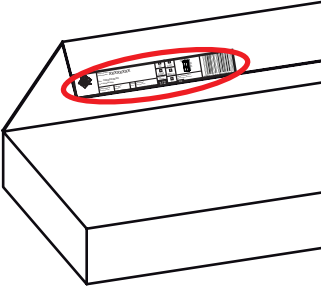

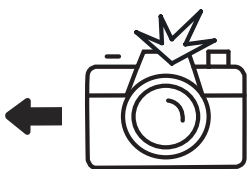

**PL - Zachowaj w razie reklamacji !!! / BG - Пазере в случай на рекламация !!! / CZ - Uchovávejte pro případ stížnosti !!! / DE - Im Falle einer Beschwerde aufbewahren !!! / EN - Keep in the event of a complaint !!! / ES - Conservar en caso de reclamación !!! / EST - Kaebuse korral hoidke alles !!! / FR - Conserver en cas de réclamation !!! / HR - Zadržite u slučaju prigovora !!! / HU - Tartsa fenn panasz esetén !!! / IT - Conservare in caso di reclamo !!! / LT - Laikykite skundo atveju !!! / LV - Saglabājiēt sūdzības gadījumā !!! / NL - Bewaren in geval van een klacht !!! / PO - Guardar em caso de reclamação !!! / RO - Păstrați în cazul unei reclamații !!! / RU - Сохранить в случае рекламации !!! / S - Föörvara vid klagomål !!! / SK - Majte v prípade reklamácie !!! / SLO - Hranite v primeru pritožbe !!! / SRB - Задржите у случају жалбе !!! / TR - Şikayet durumunda saklayın !!! / UKR - Зберігати у разі скарги !!!**

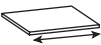

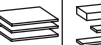

Nazwa wyrobu: Product Name: <b>XXXXXXXXXX</b>			
Kolor: <b>XXXXXXXXXX</b> Color:XXXXXXXXXX			
Data produkcji: Production date:	Pakujący: Packager:	Szko: Glass:	Kod paczki: Code packages:
<b>0000-00-00</b>	<b>xx0/xx0</b>	<b>0</b>	<b>0xxxxx00-000-0/0</b>

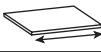
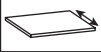
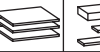
	CODE				
1	Arko02_02	543	400	1	1/2
2	Arko02_05	509	500	1	1/2
3	Arko02_11	509	108	1	1/2
4	Arko02_10	1272	397	1	2/2
5	Arko02_03	1956	400	1	2/2
6	Arko02_06	508	356	3	1/2
7	Arko02HDF_01	1968	519	1	2/2
8	Arko02_04	1956	400	1	2/2
9	Arko02_01	543	400	1	1/2
10	Arko02_07	1988	70	1	2/2
11	Arko02_08	1988	70	1	2/2
12	Arko02_09	618	397	1	2/2
13					
14					
15					

	CODE				
16					
17					
18					
19					
20					
21					
22					
23					
24					
25					
26					
27					
28					
29					
30					

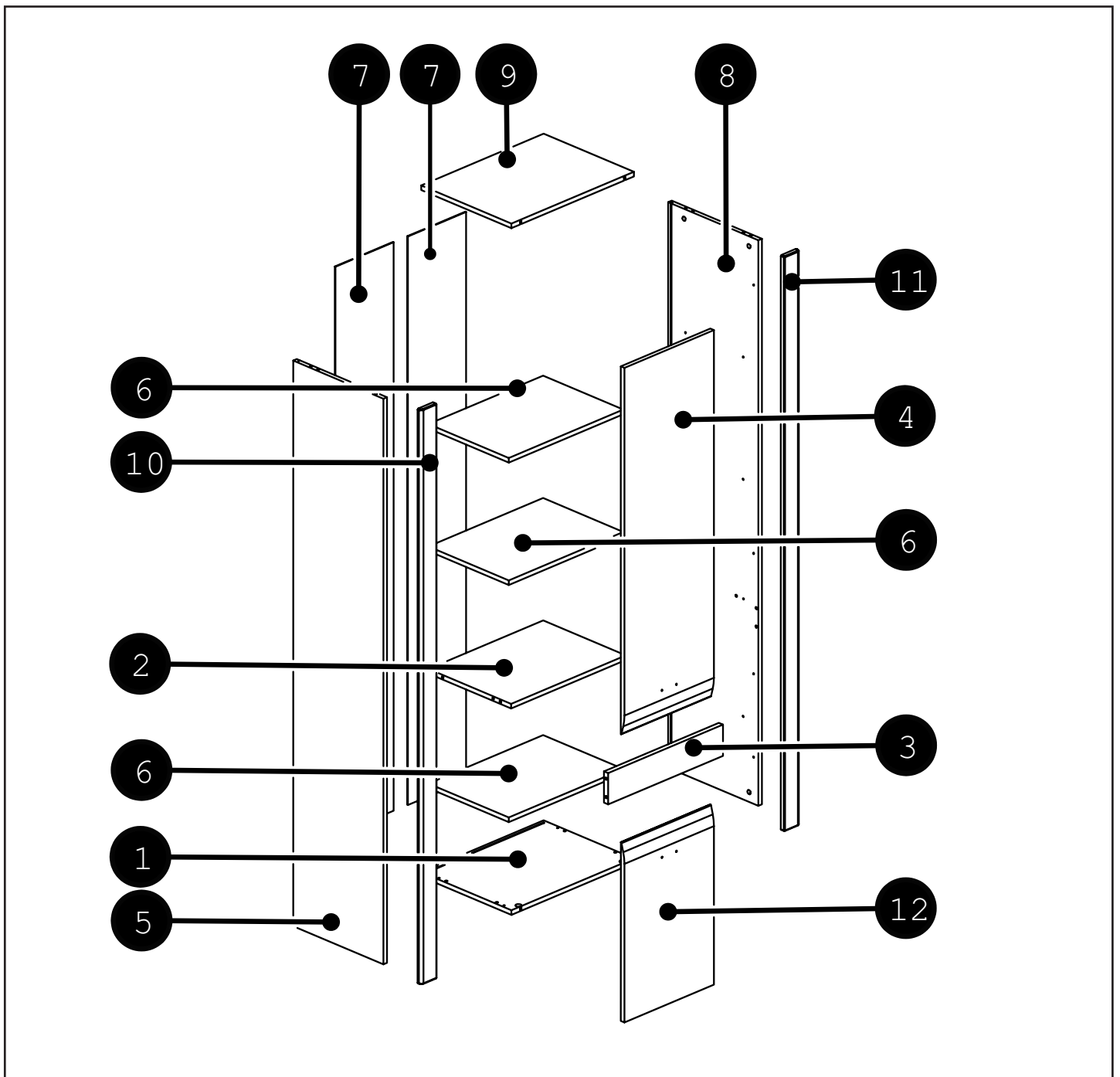

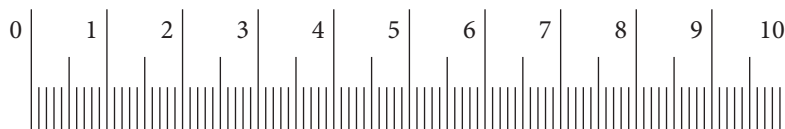
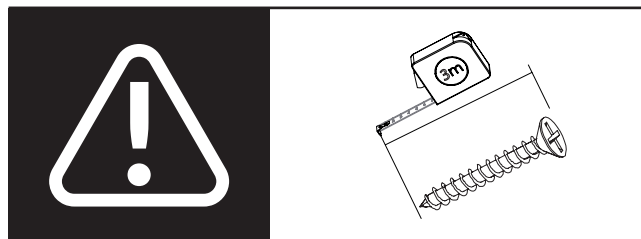
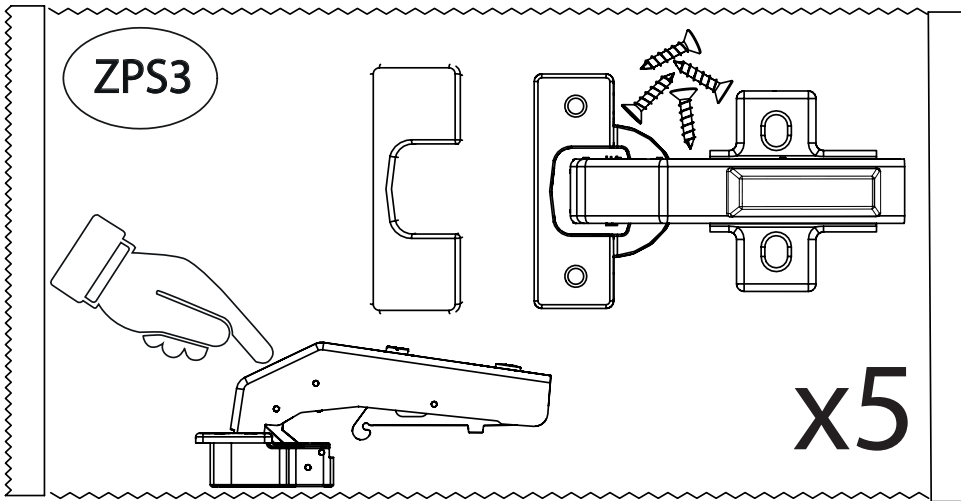
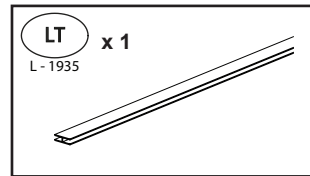
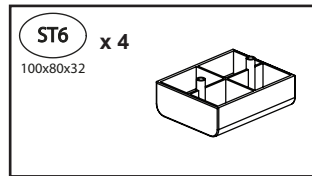
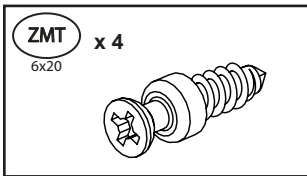
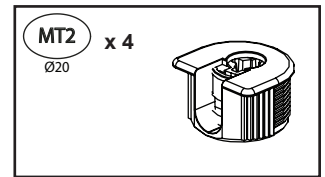
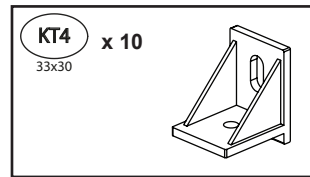
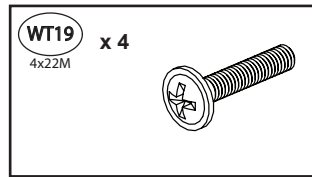
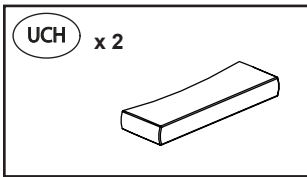
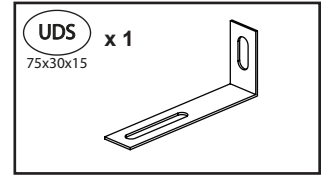
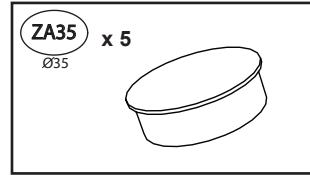
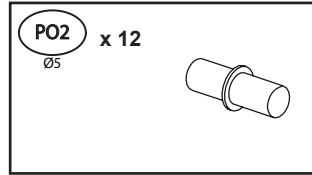
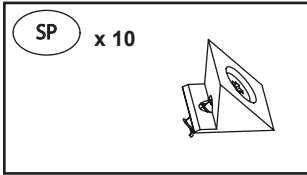
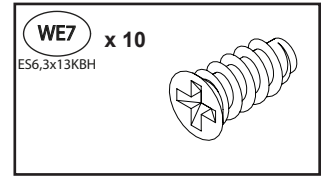
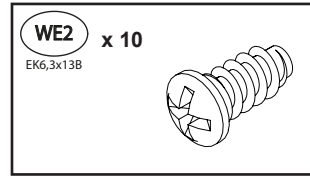
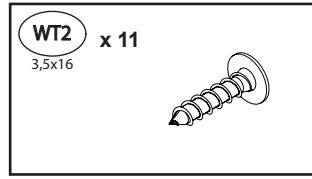
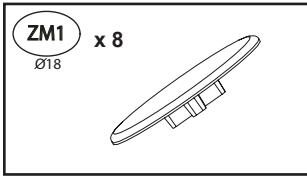
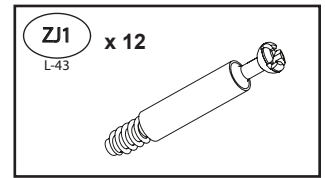
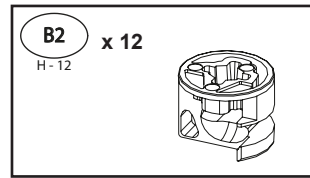
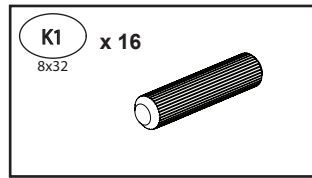
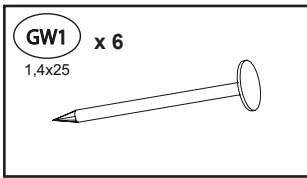

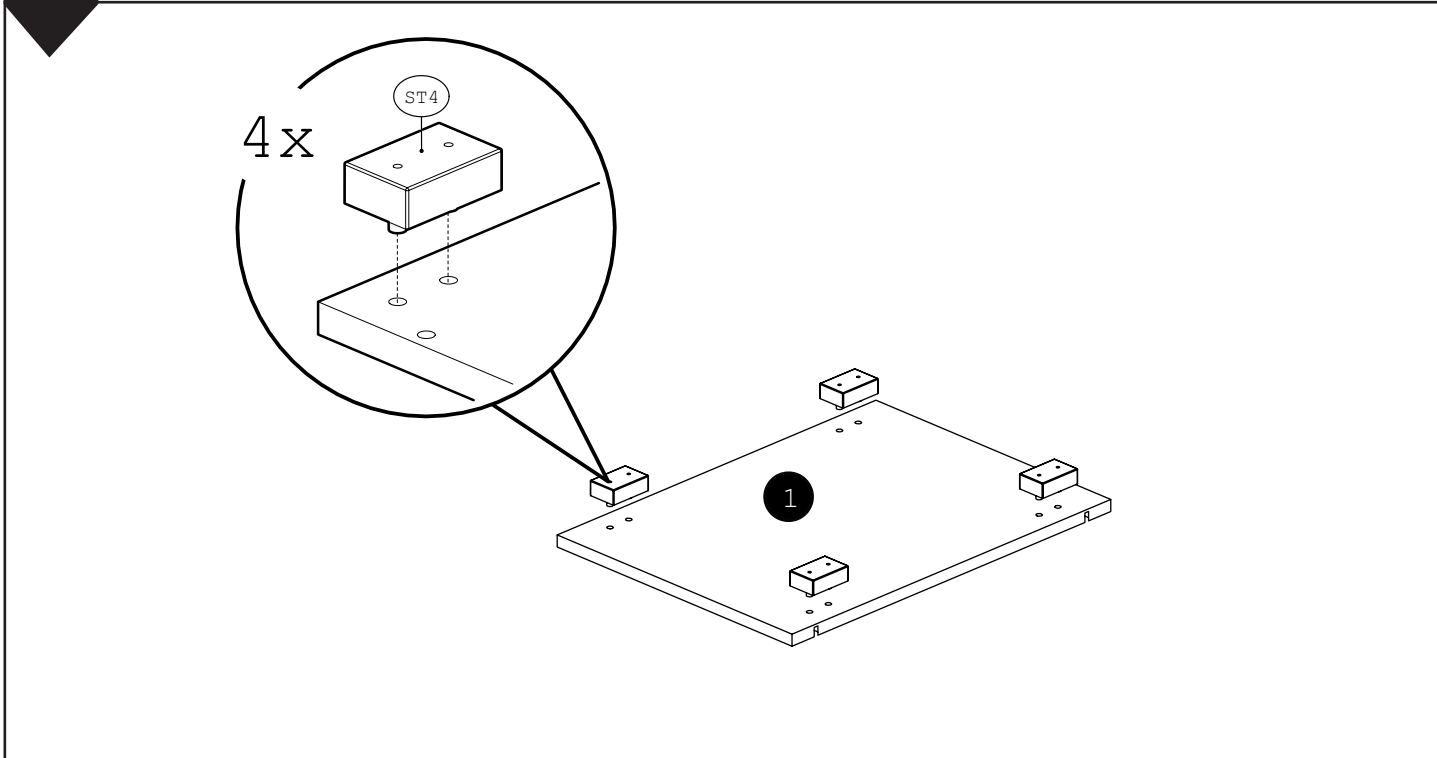
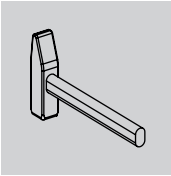
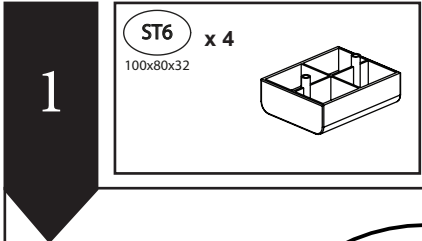
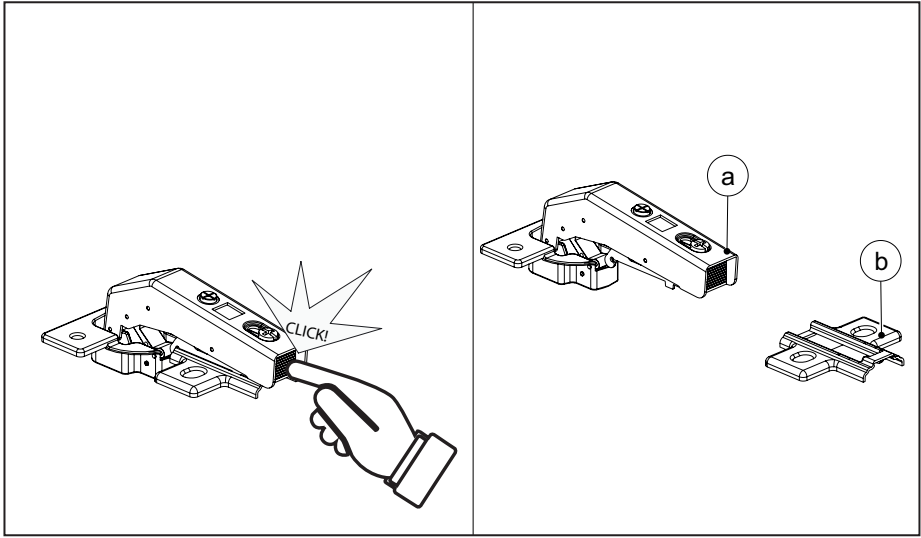
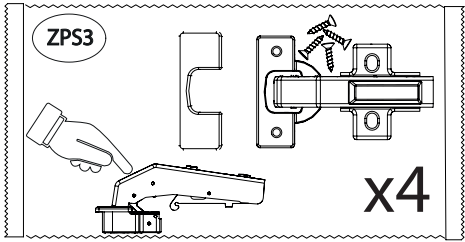
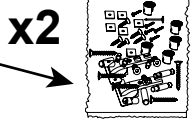
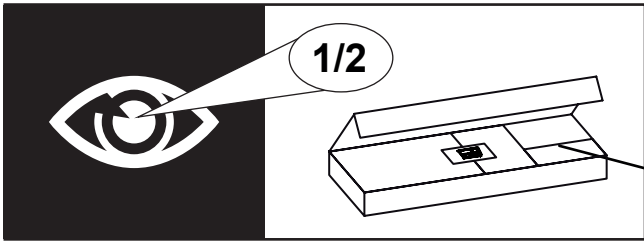

2

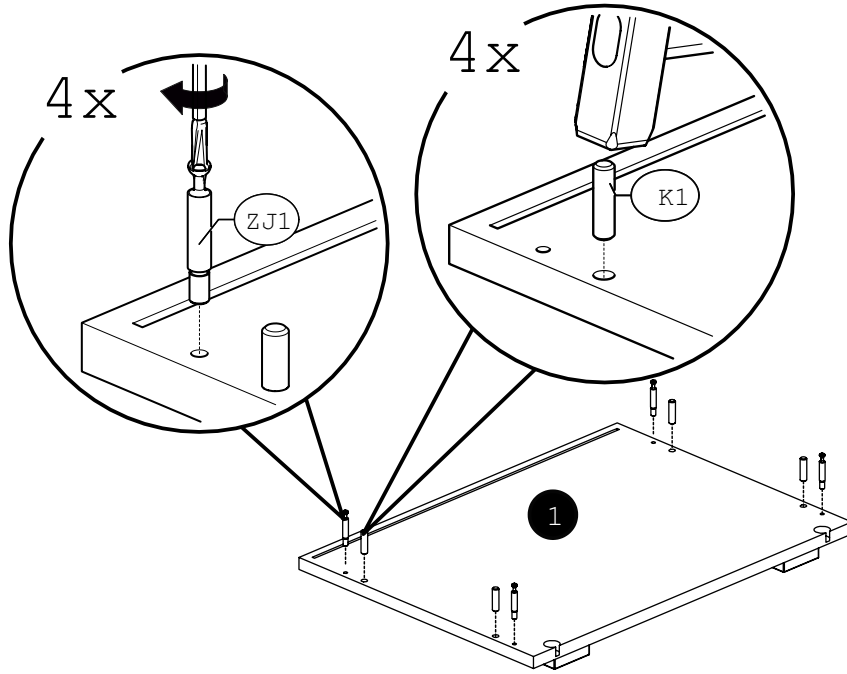
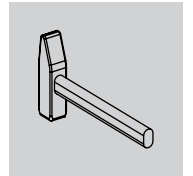
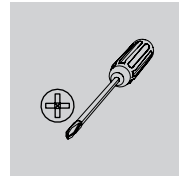
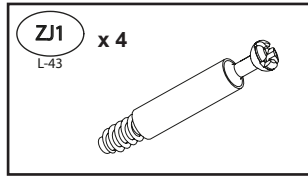
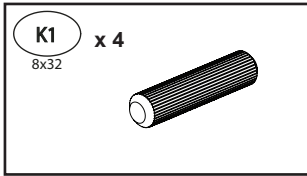

3

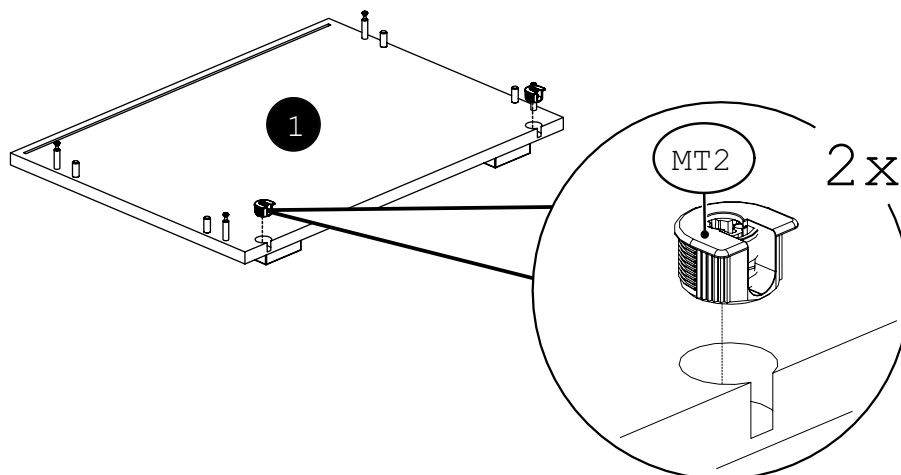
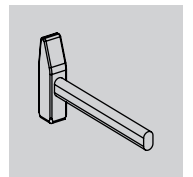
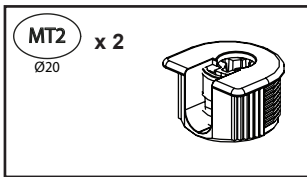

4

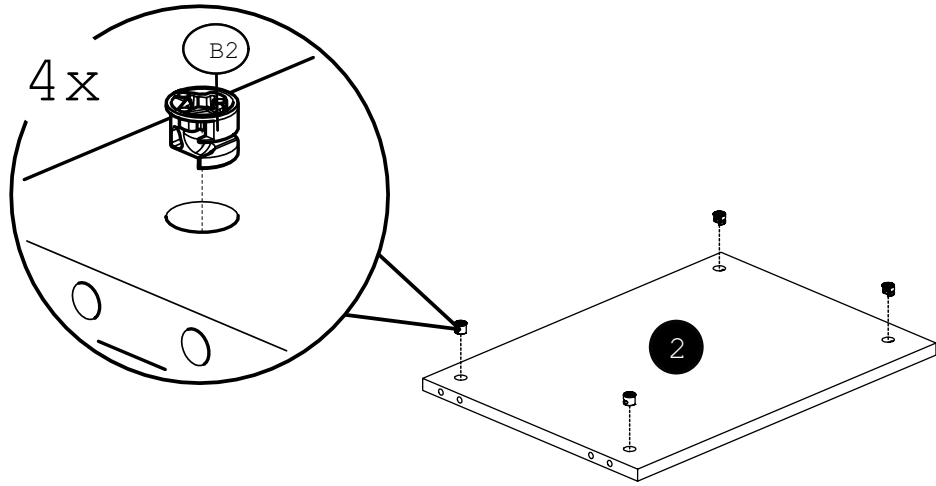
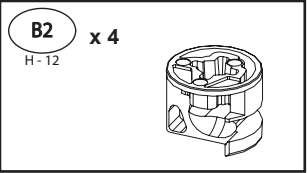

5

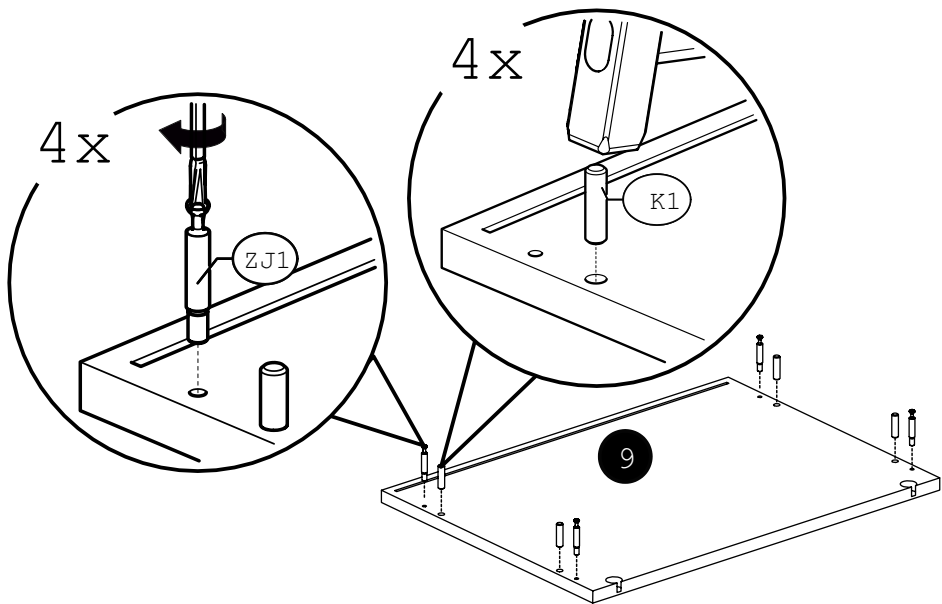
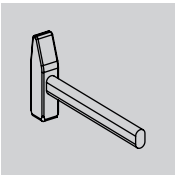
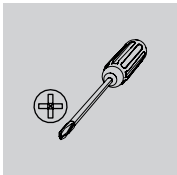
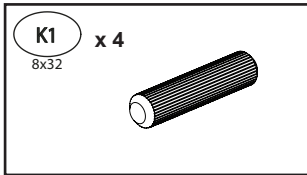
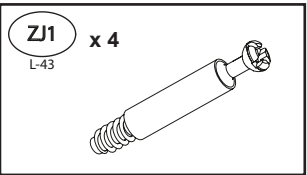

6

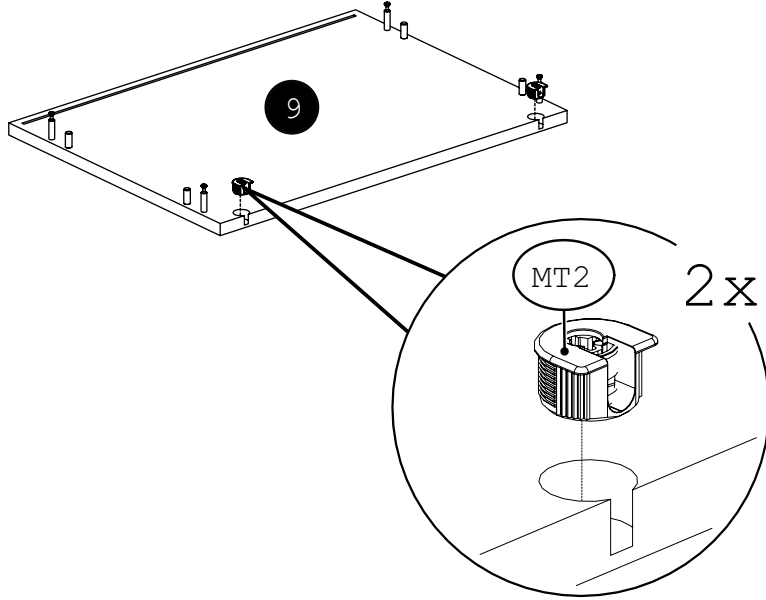
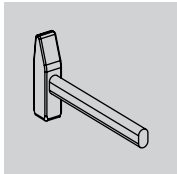
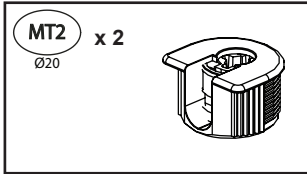

7

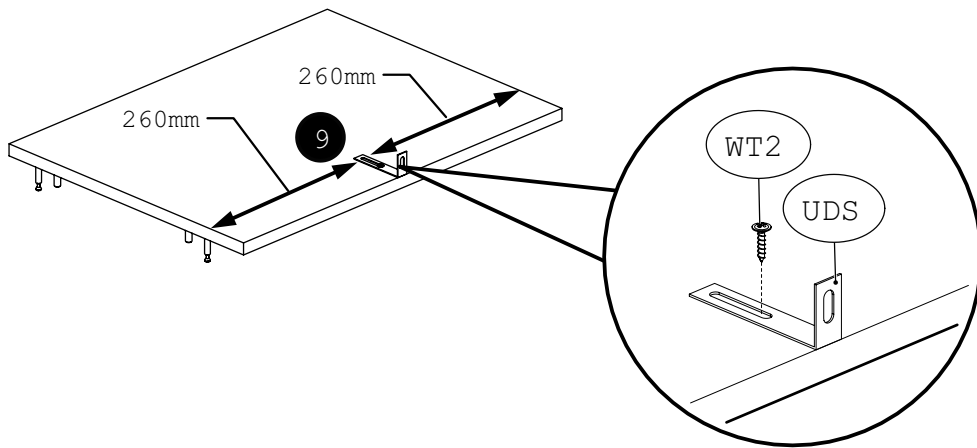
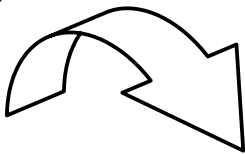
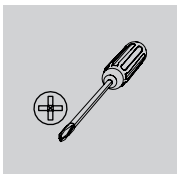
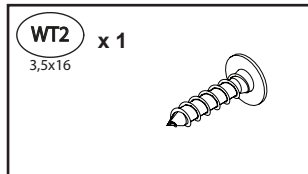
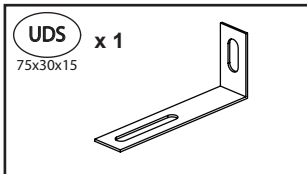



8

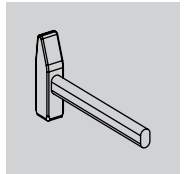
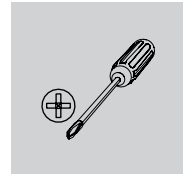
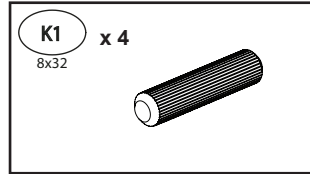
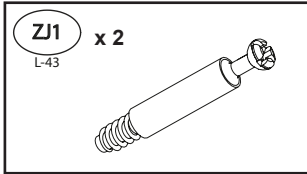

2/2

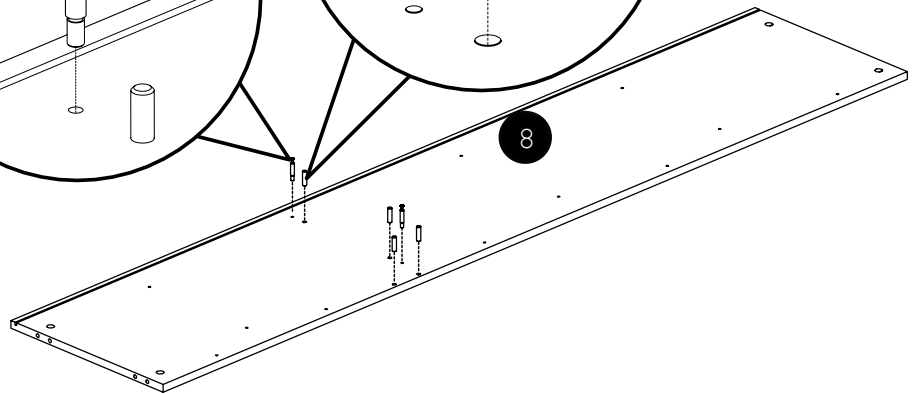
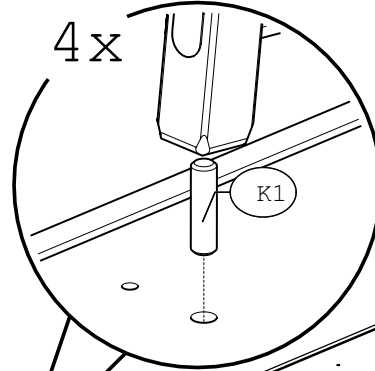
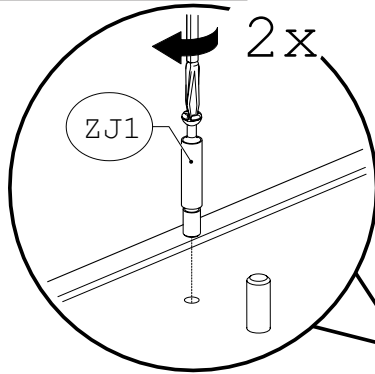
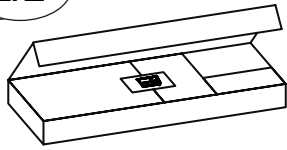

9

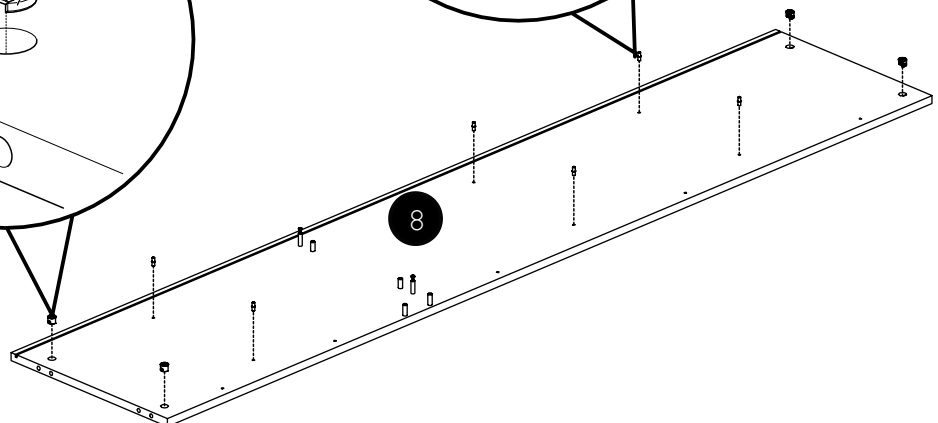
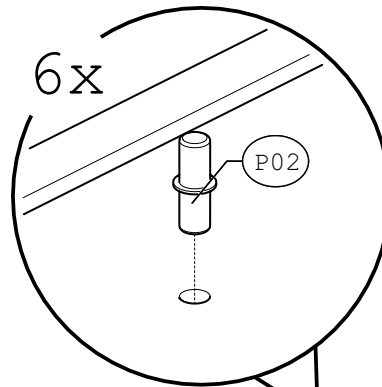
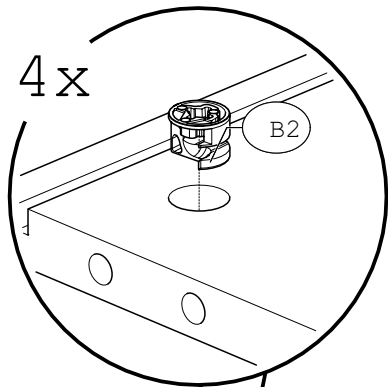
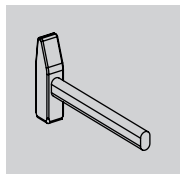
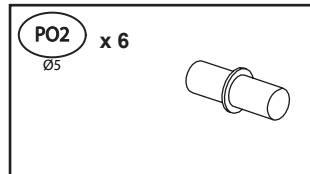
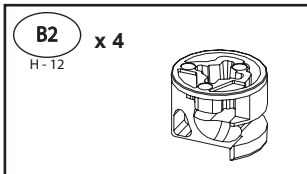

10

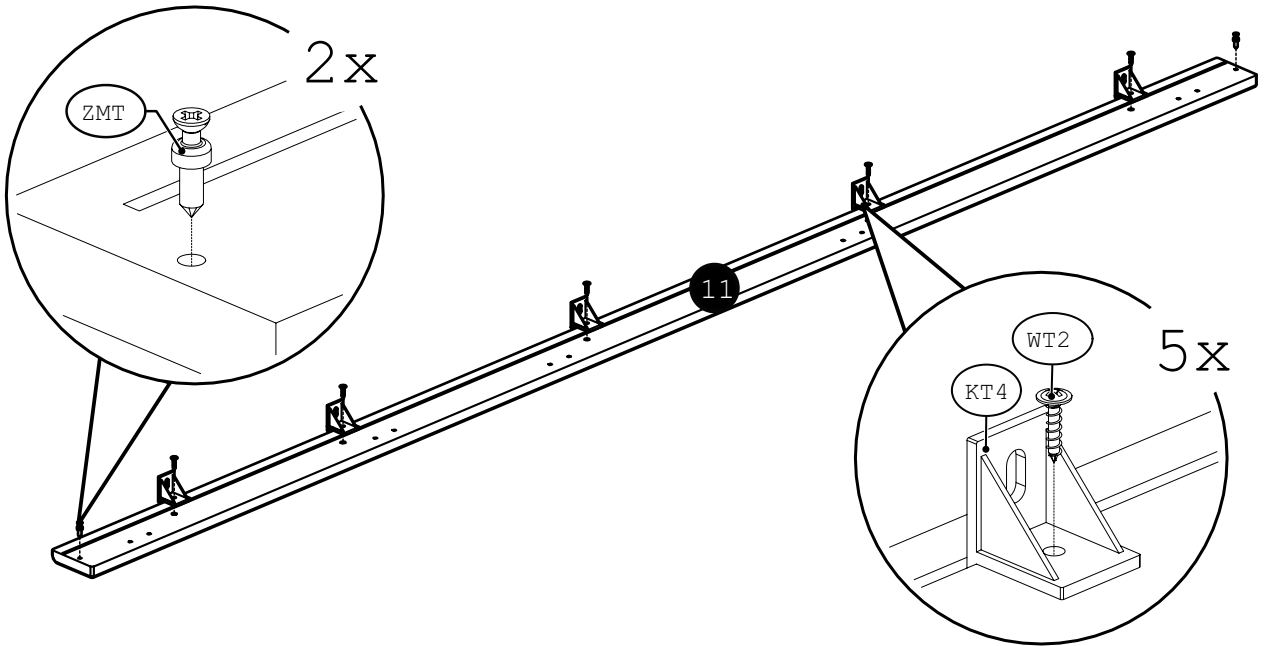
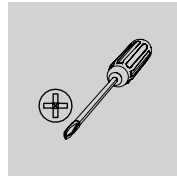
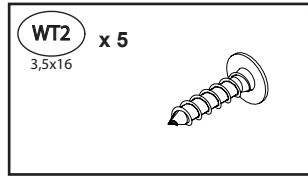
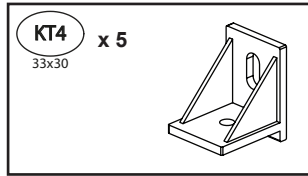
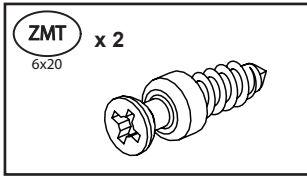

11

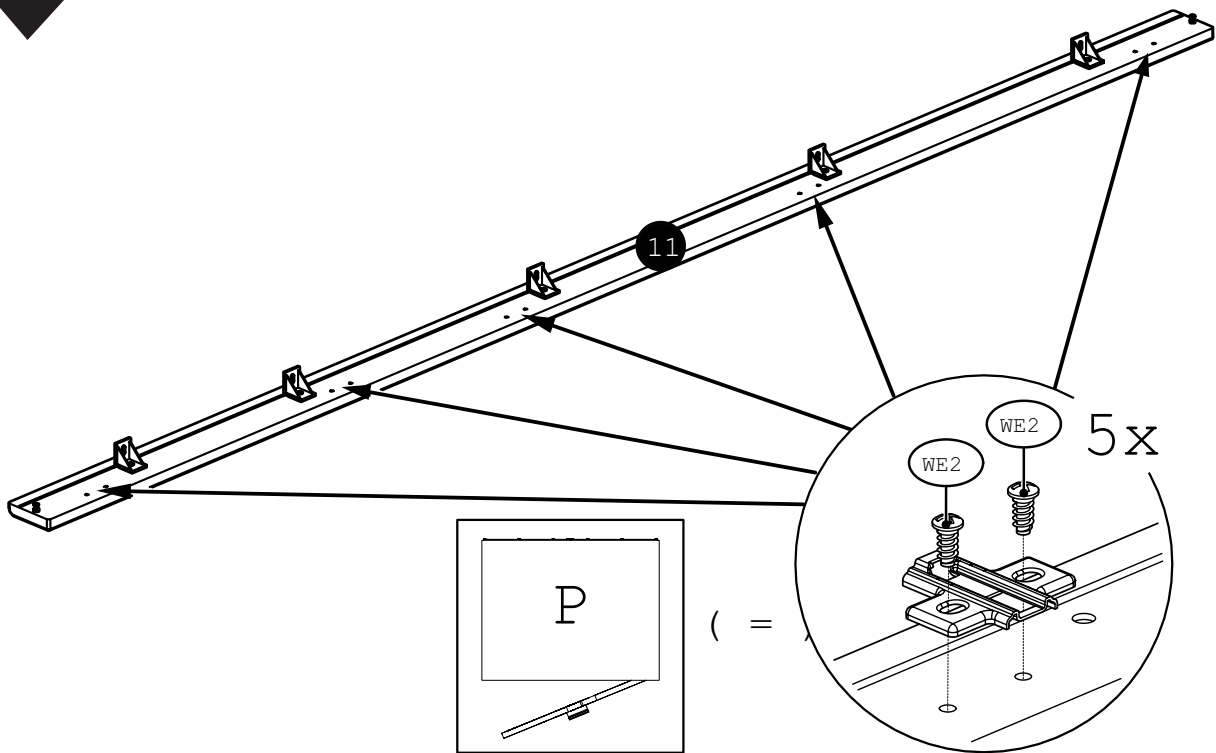
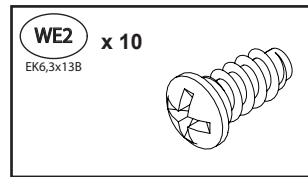
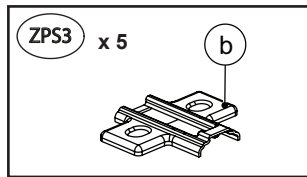

12

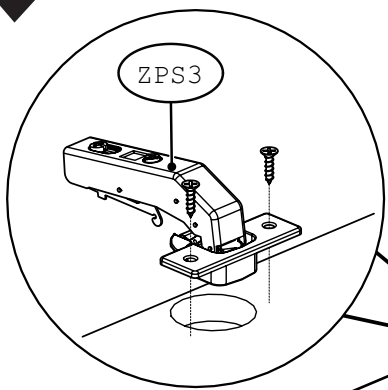
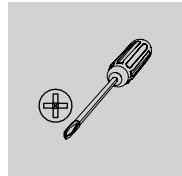

( =

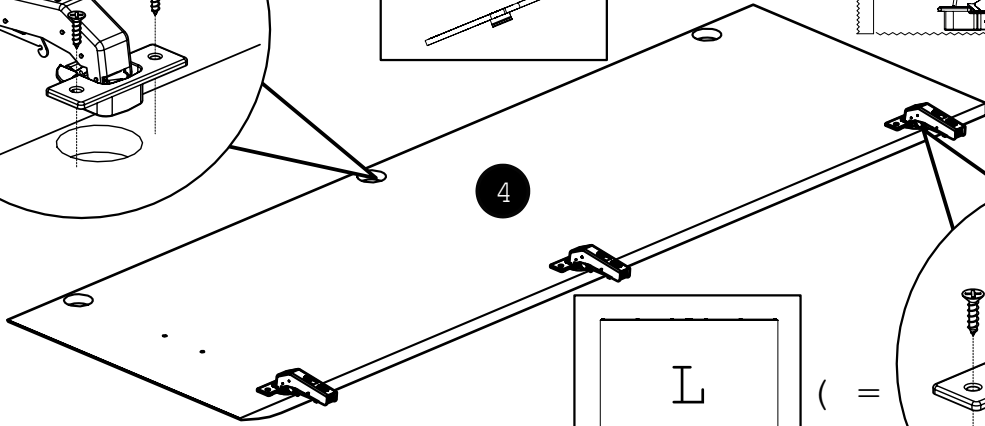
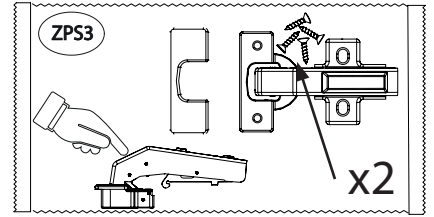
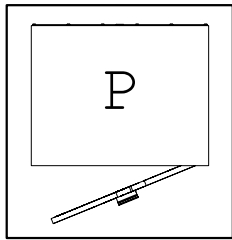

4

( =

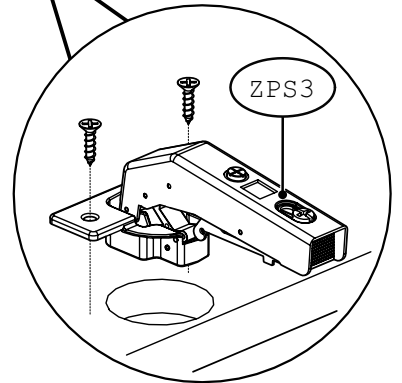
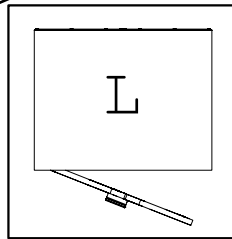

13

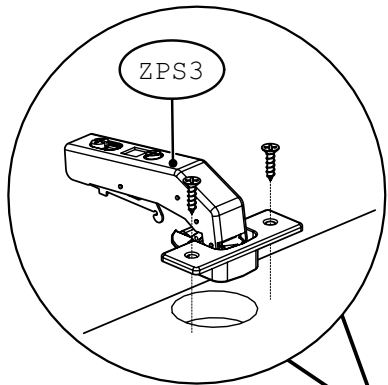
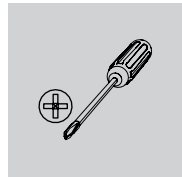

( =

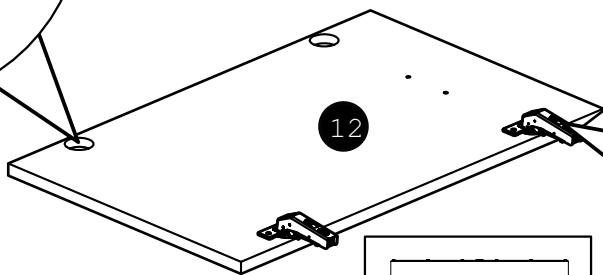
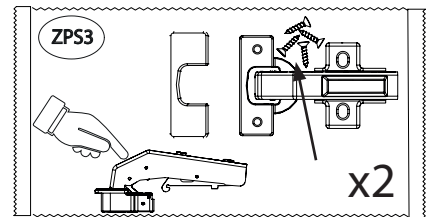
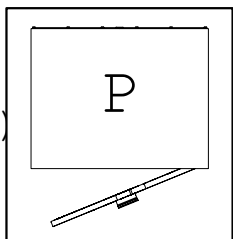

12

( =

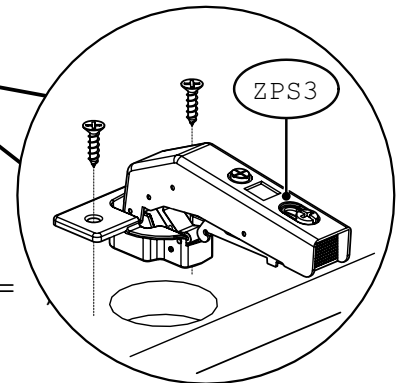
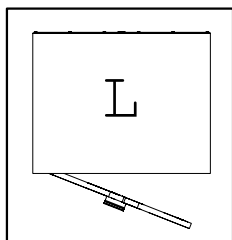

14

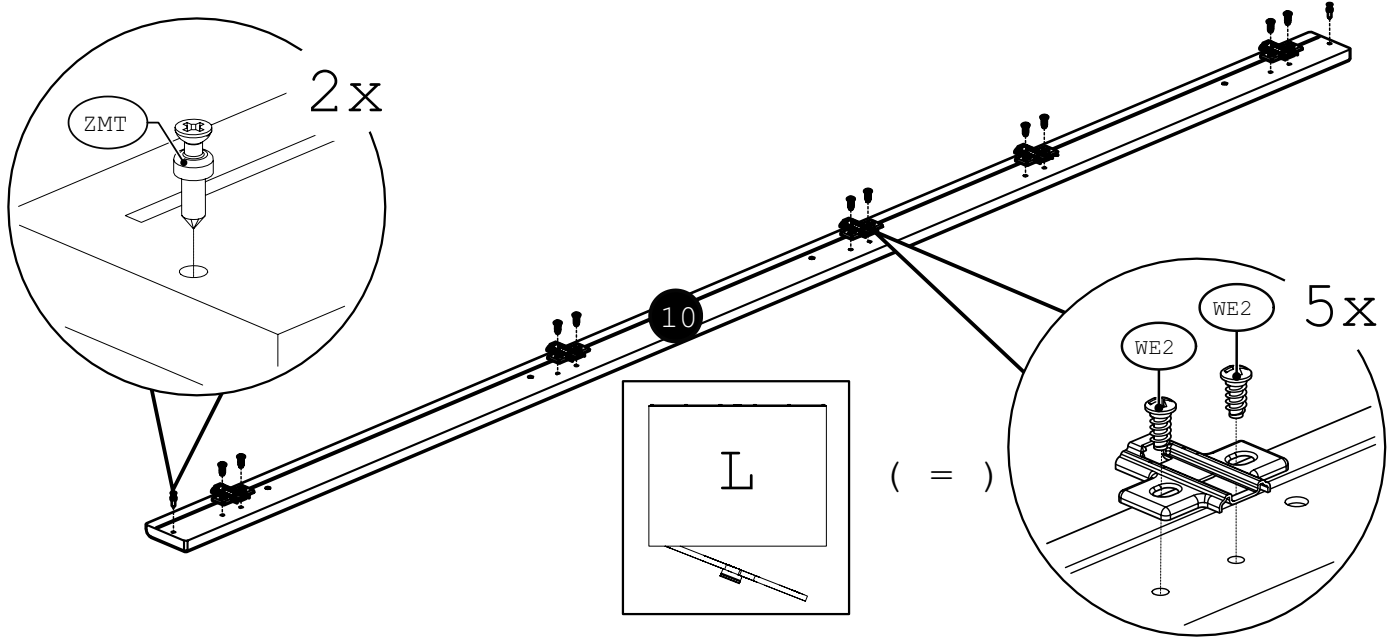
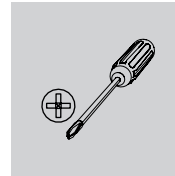
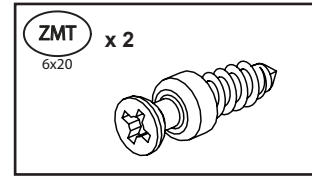
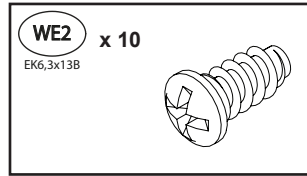
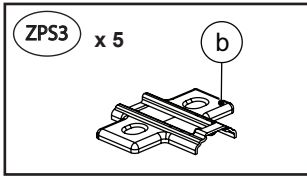

15

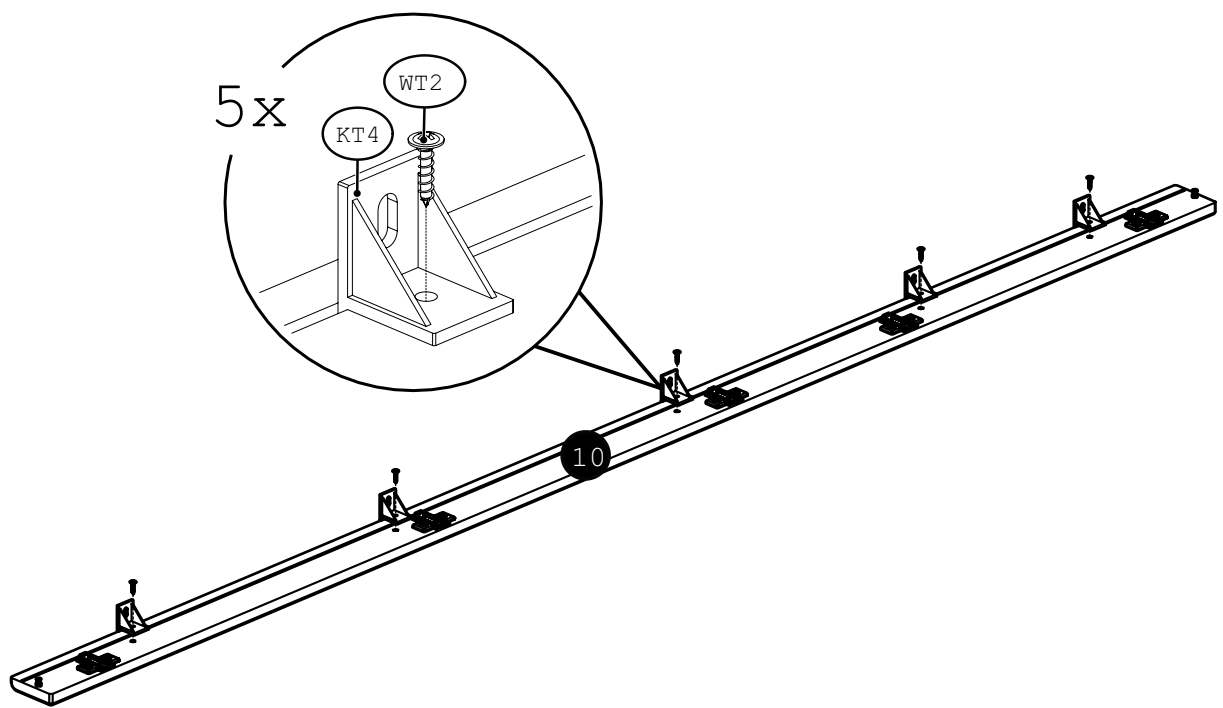
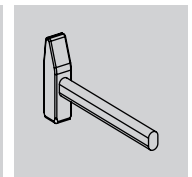
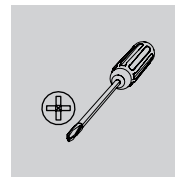
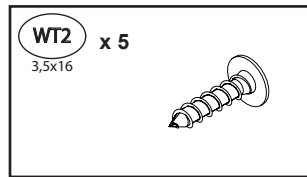
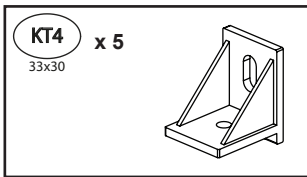

16

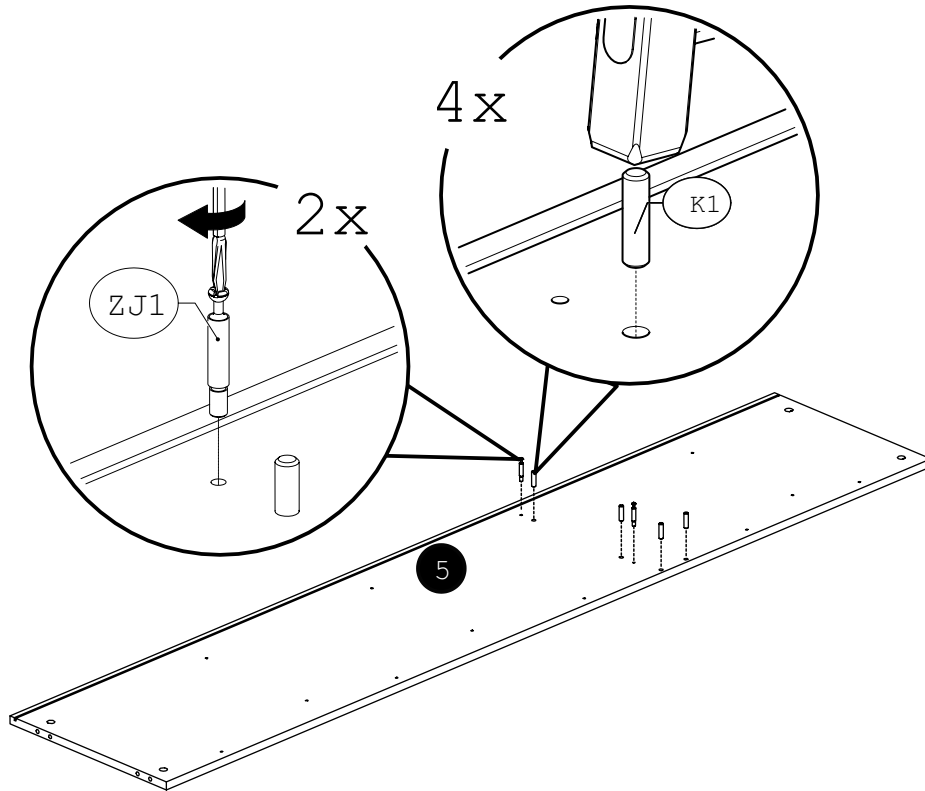
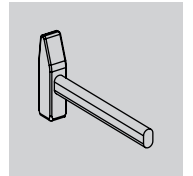
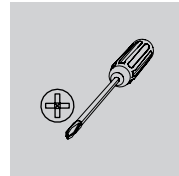
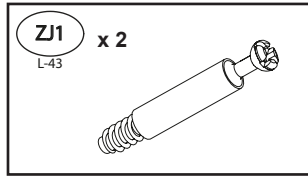
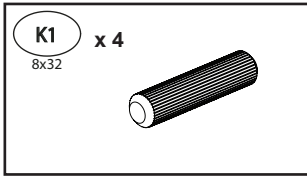

17

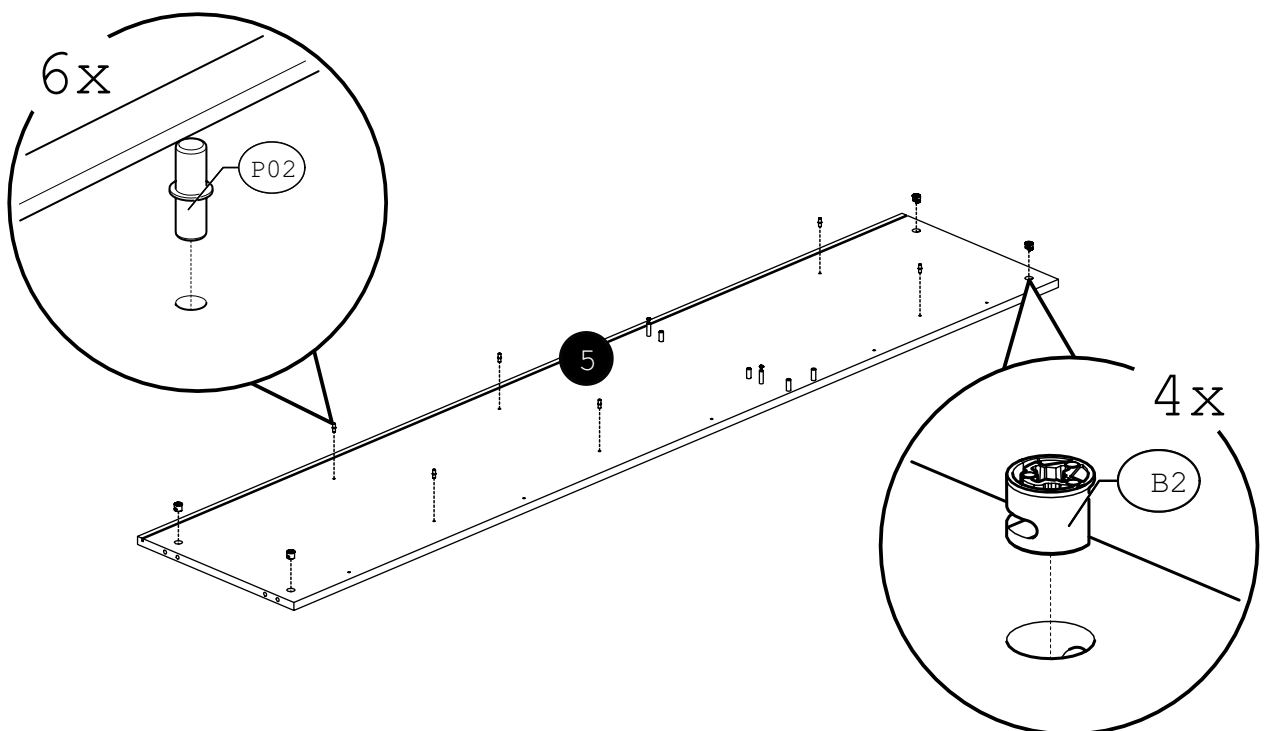
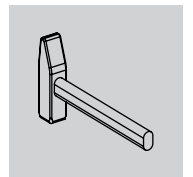
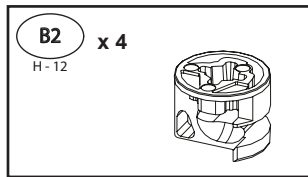
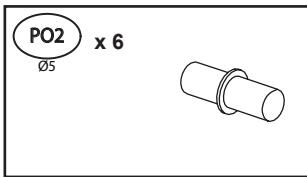

18

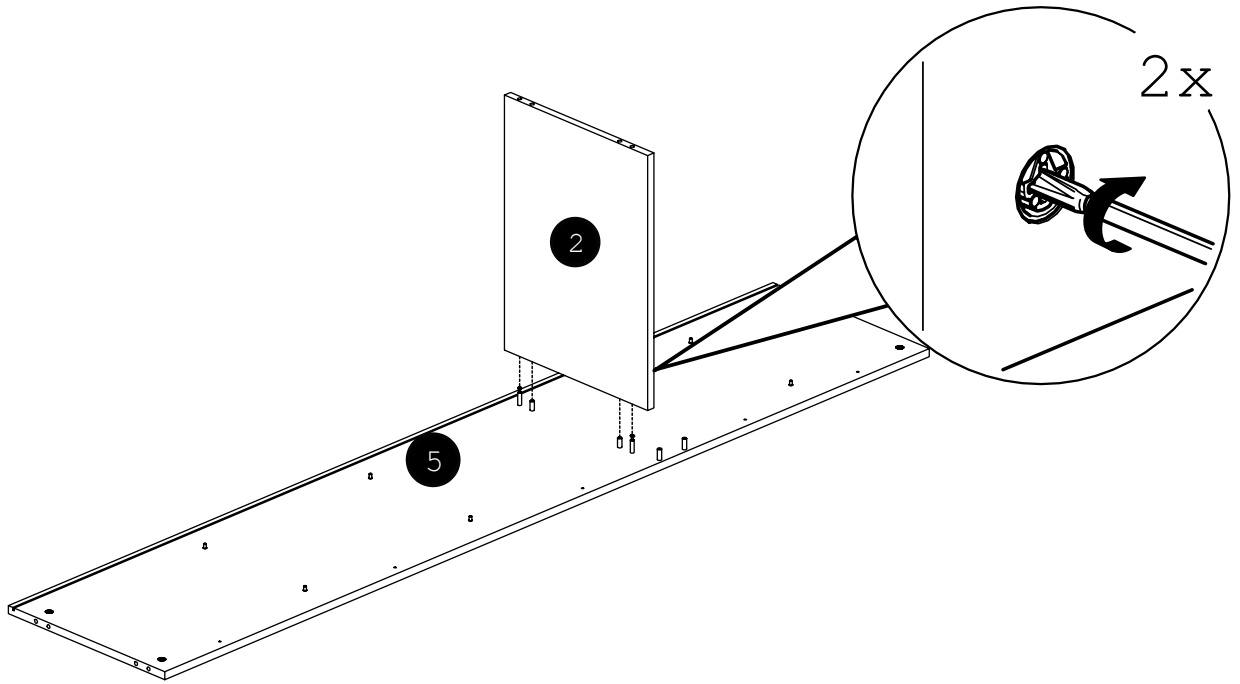
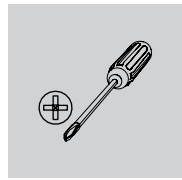

19

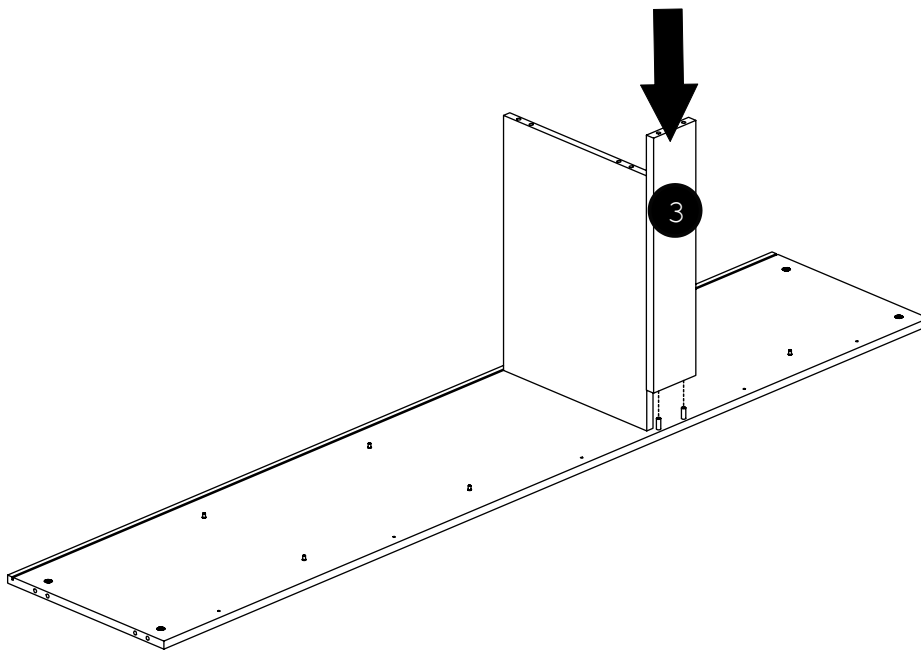

20

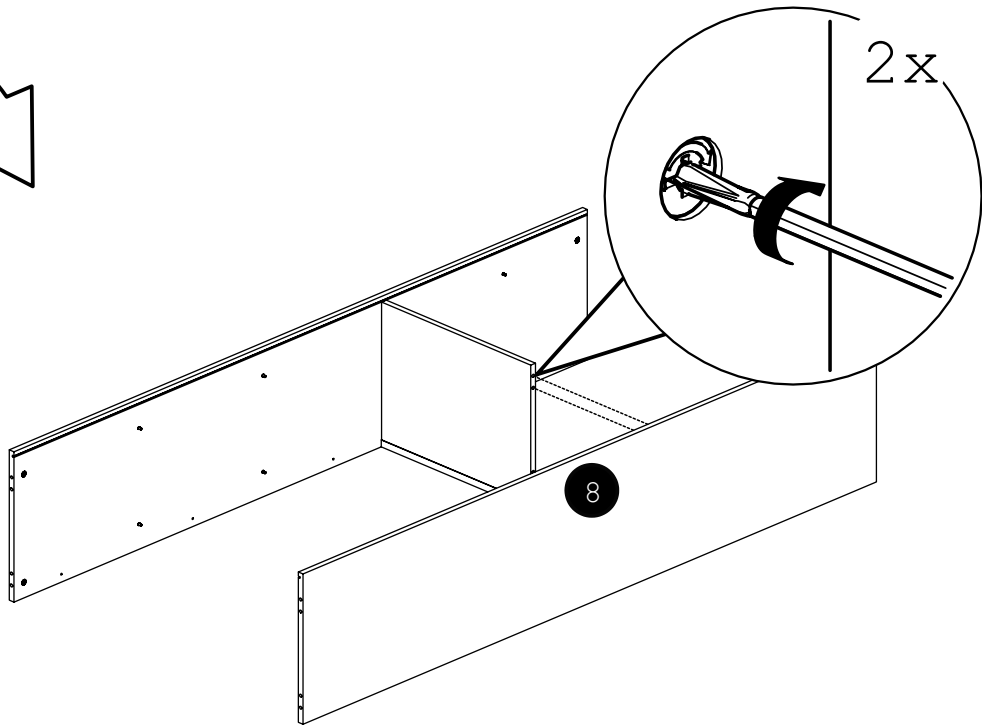
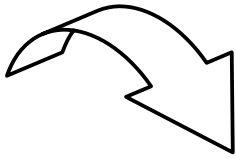
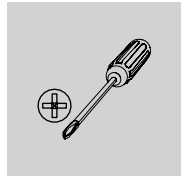

21

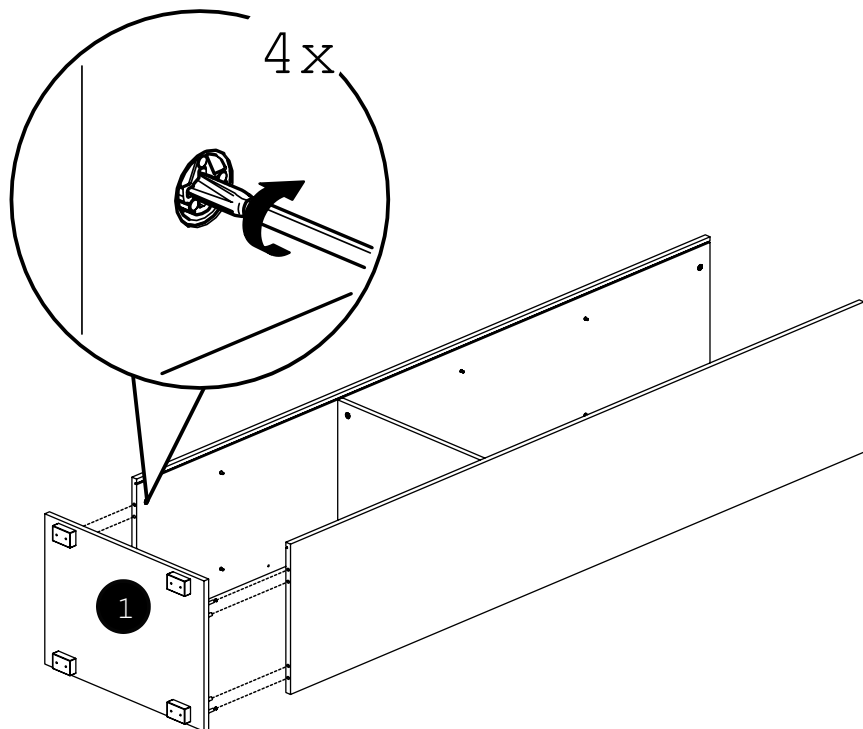
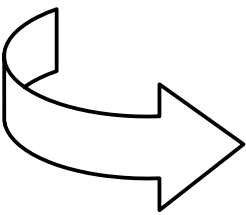
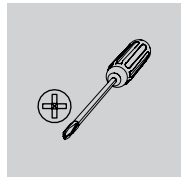

22

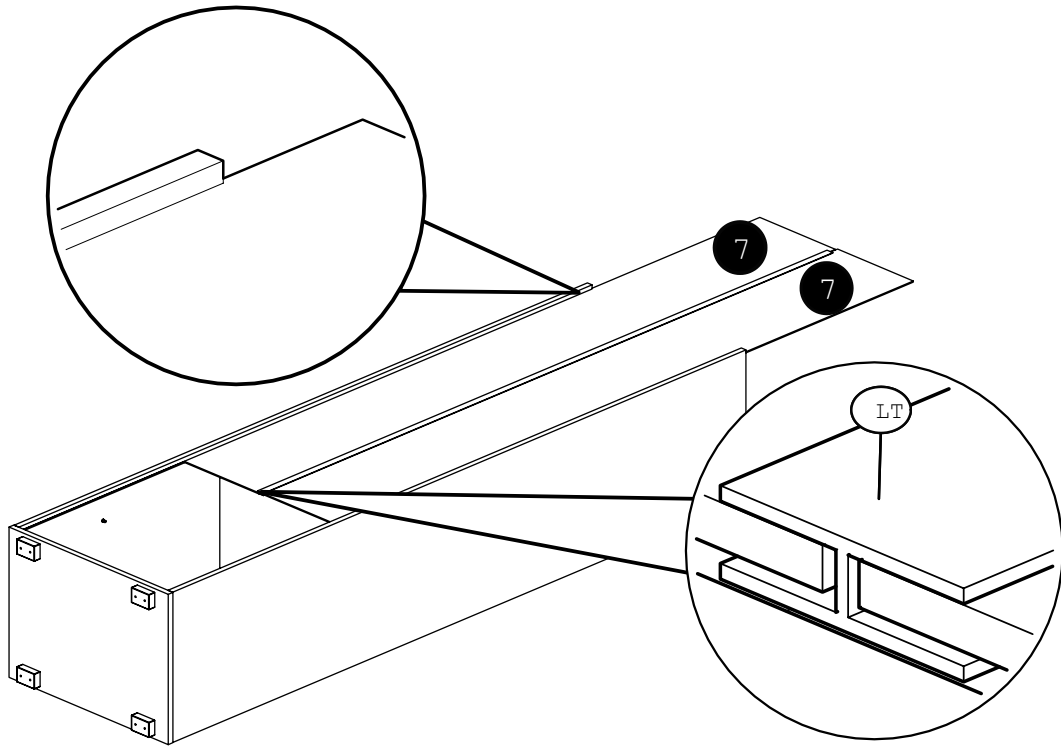
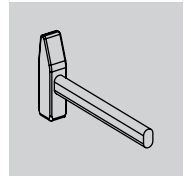
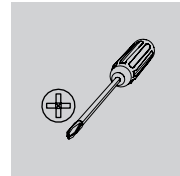
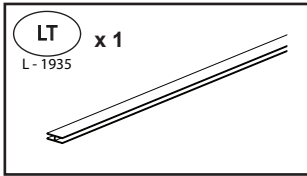

23

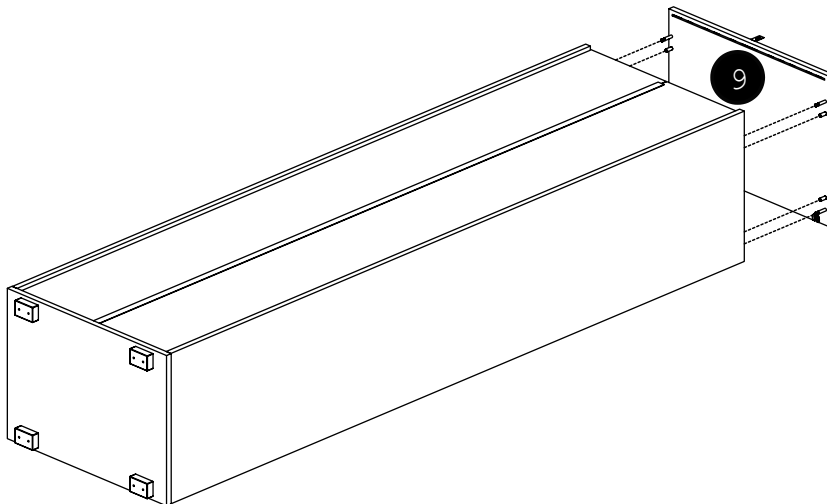
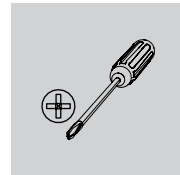



24

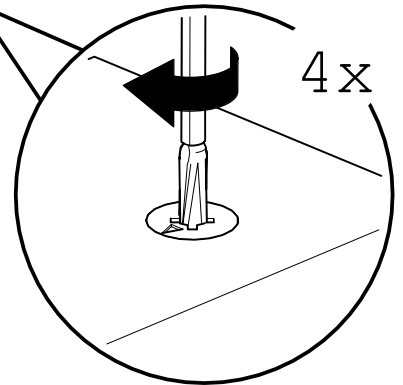
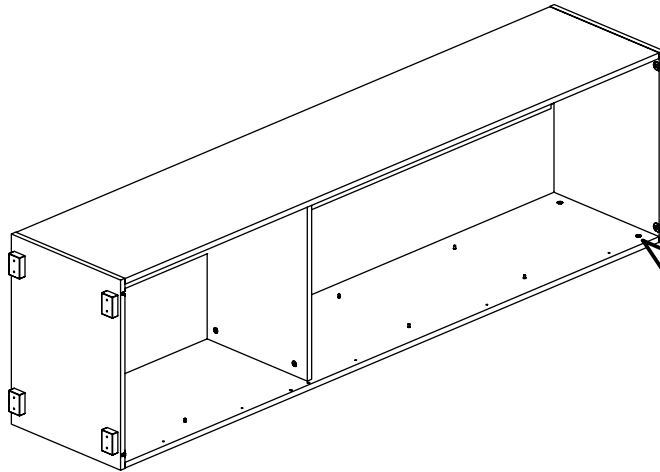
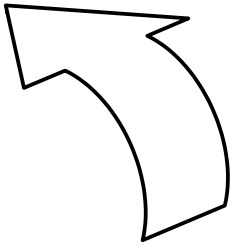
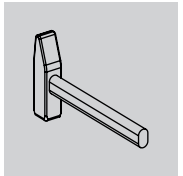
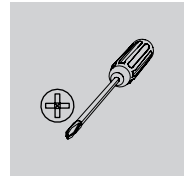

25

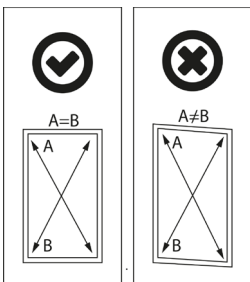
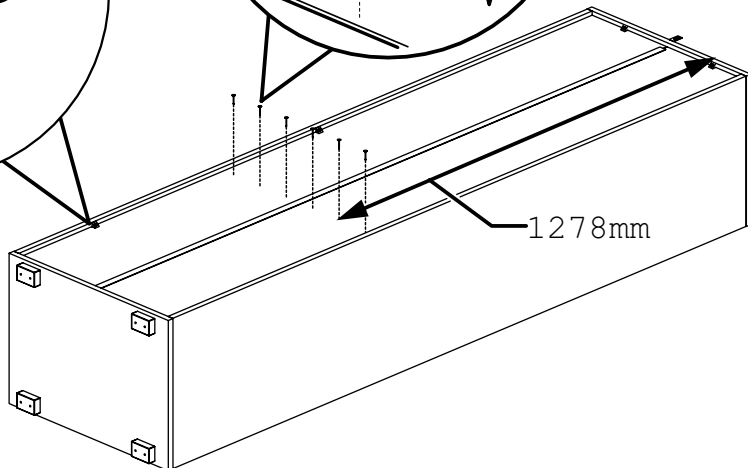
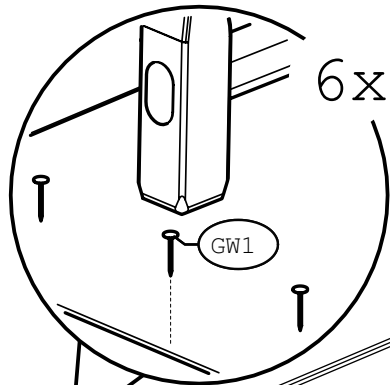
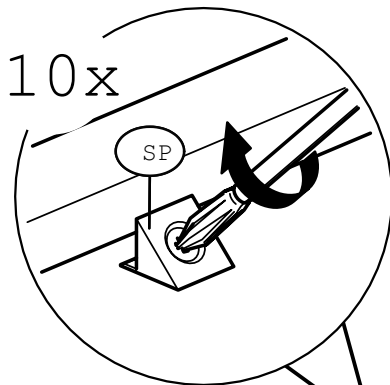
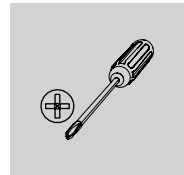
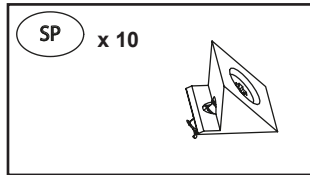
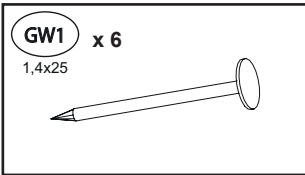

26

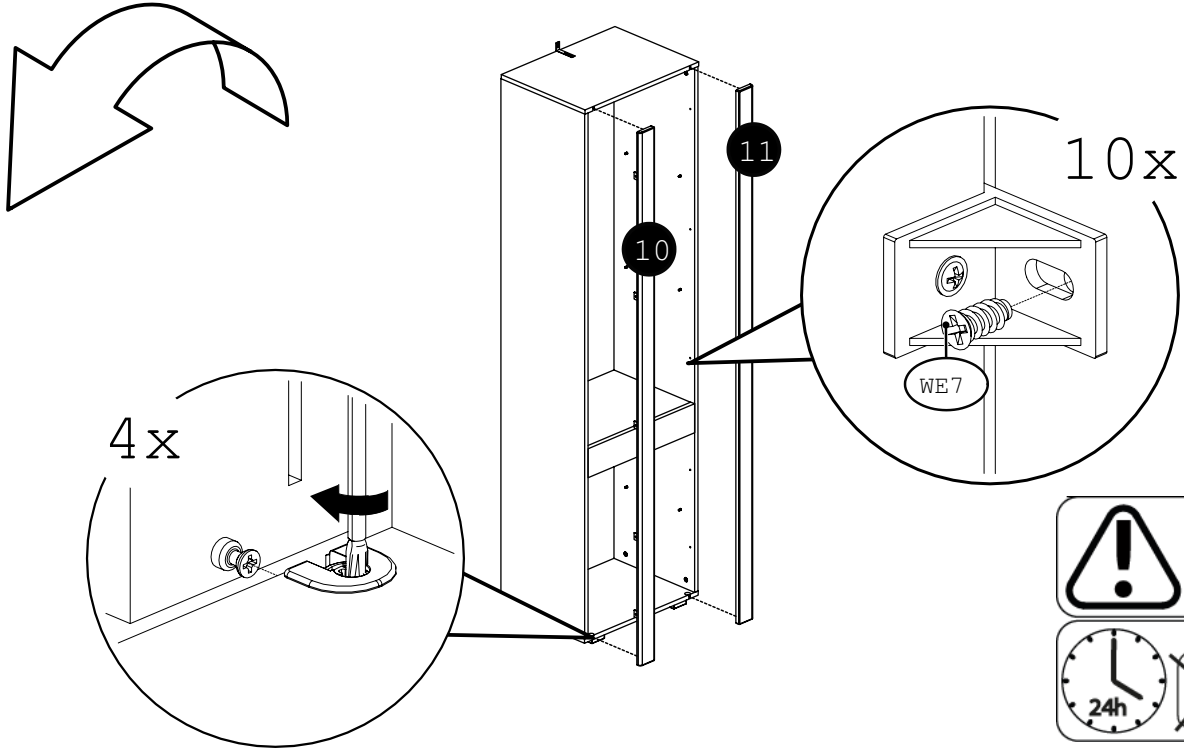
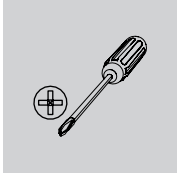
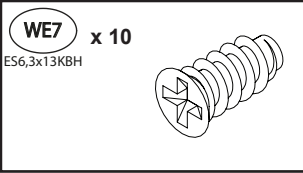

27

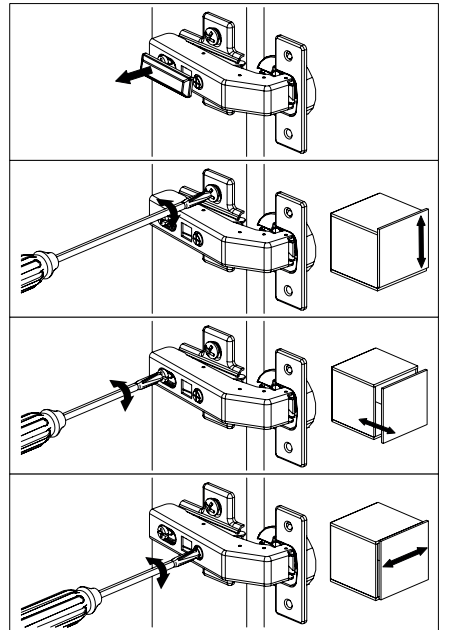
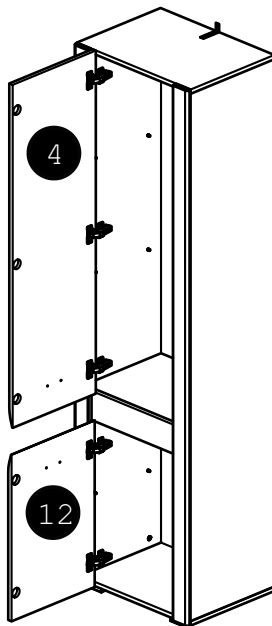
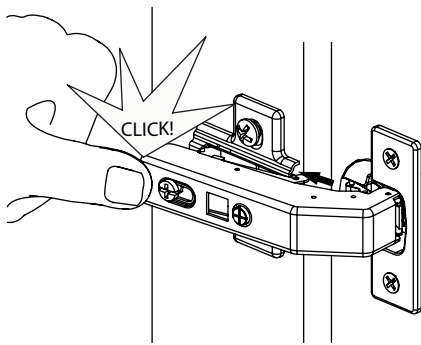
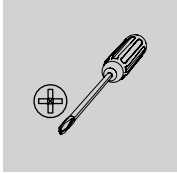

28

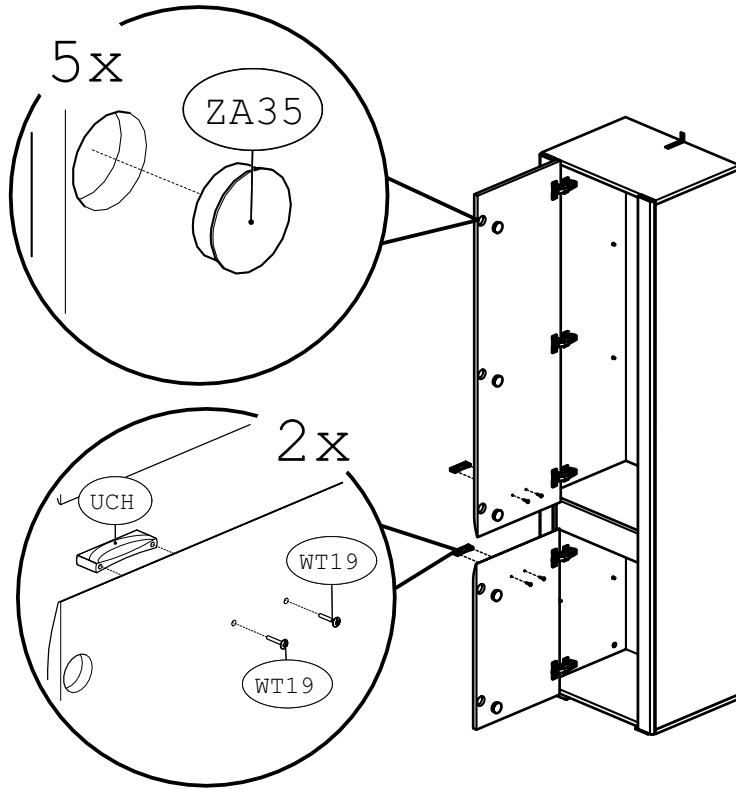
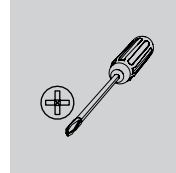
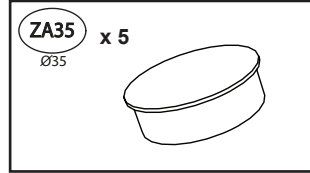
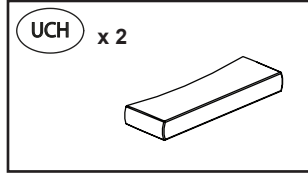
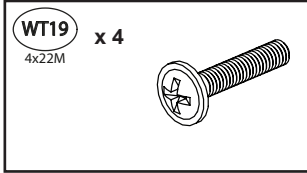

29

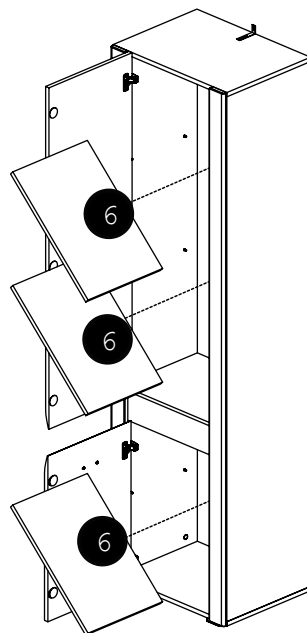
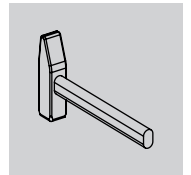
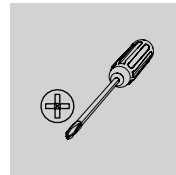

30

ZM1 x 8  
Ø18

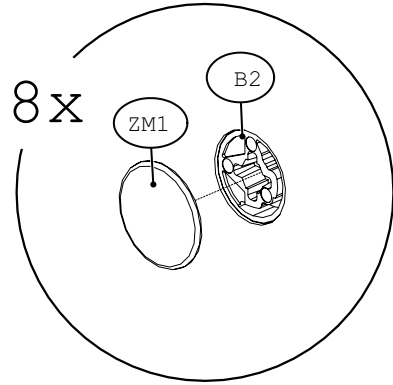
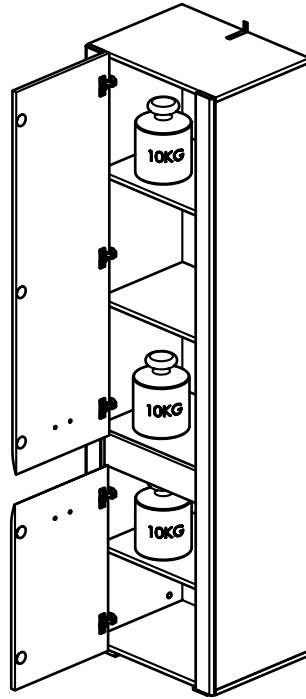
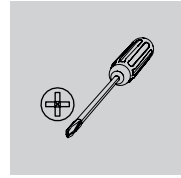
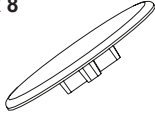



PL –  
Przed zawieszeniem mebla, lub przymocowaniem go do ściany (w celu zabezpieczenia przed przewróceniem), sprawdź wcześniej rodzaj i wytrzymałość ściany. Dobierz odpowiednie kołki i wkręty do rodzaju ściany. W przypadku wątpliwości skontaktuj się ze specjalistą. Montaż musi zostać wykonany przez osobę kompetentną. UWAGA!!! Jeżeli do wyrobu są dołączone kołki rozporowe z wkrętami, to są one przeznaczone tylko i wyłącznie do ścian wykonanych z litych i jednorodnych materiałów.

BG –  
Преди да закачите мебела, или преди да го прикрепите към стената (за да се предотврати падането), проверете предварително вида и силата на стената. Използвайте дюбели и винтове подходящи за вида на стената. В случай на съмнение, консултирайте се със специалист. Монтажът трябва да бъде извършен от компетентно лице. ВНИМАНИЕ!!! Ако с продукта са доставени дюбели и винтове, те са предназначени единствено за стени, изработени от твърди и еднородни материали.

CZ –  
Před zavěšením nábytku nebo jeho připevněním ke zdi (za účelem zajištění před převrácením) dříve zkontrolujte druh a odolnost stěny. Vyberte k druhu stěny vhodné hmoždinky a šrouby. V případě pochybností kontaktujte specialistu. Montáž musí být provedena kompetentní osobou. POZOR!!! Pokud jsou k výrobku přiloženy hmoždinky se šrouby, jsou určeny jen a výhradně do stěn zhotovených z masivních a homogenních materiálů.

DE –  
Bevor Sie ein Möbelstück an einer Wand aufhängen oder befestigen (um es gegen Umkippen zu sichern), prüfen Sie Art und Tragfähigkeit der Wand. Wählen Sie die für die Wand geeigneten Dübel und Schrauben. Im Zweifelsfall kontaktieren Sie bitte einen Fachmann. Die Montage muss durch eine sachkundige Person ausgeführt werden. ACHTUNG!!! Wenn der Ware Dübel und Schrauben beiliegen, sind sie ausschließlich zur Anwendung an Wänden aus massiven und einheitlichen Materialien bestimmt.

EN –  
Before suspending or fixing furniture to the wall (in order to prevent falling over), check the type and strength of the wall. Select wall plugs and screws appropriate for the given type of the wall. In the case of doubts, contact a specialist. The installation must be performed by a competent person. WARNING!!! If the rawplugs with screws are attached to the product, then they are intended only for walls made of solid and homogeneous materials.

ES –  
Antes de colgar o fijar el mueble en el muro (a fin de proteger contra el vuelco del mueble), compruebe de antemano la naturaleza y la resistencia de la pared. Seleccione tacos y tornillos adecuados para el tipo de la pared. En caso de duda, consulte a un especialista, debiendo efectuar este montaje una persona competente. ¡¡¡ATENCIÓN!!! En caso el producto esté acompañado de tacos y tornillos, éstos se destinan solamente a los muros hechos con materiales sólidos y homogéneos.

EST –  
Enne mööbli riputamist või kinnitamist seinale (ümbermineku tõkestamiseks), tuleks enne uurida seina olemust ja tugevust. Paigaldada tüüblid ja kruvid vastavalt seinale. Kahtluse korral konsulteeruda spetsialistiga. Paigaldus tuleb teostada pädeva isiku poolt. TÄHELEPANU!!! Kui toodega on kaasas tüüblid kruvidega on need mõeldud ainult tahkete ja homogeenest materjalidest valmistatud seintele.

FR –  
Avant de suspendre le meuble ou de le fixer au mur (dans le but d'éviter un renversement), vérifiez au préalable le type et la résistance du mur. Utilisez les chevilles et les vis adaptées au type de mur. En cas de doute, veuillez contacter un spécialiste. Le montage doit être réalisé par une personne compétente. ATTENTION !!! Si l'ensemble contient des chevilles avec des vis, elles sont adaptées uniquement pour les murs constitués de matériaux pleins et homogènes.

HR –  
Prije kačenja nameštaja ili montaže na zidu (u cilju zaštite od prevrtanja), provjerite vrstu zida i njegovu otpornost. Izaberite odgovarajuće šrafove i uvijače za određenu vrstu zida. U slučaju nejasnoća, kontaktirajte stručnjaka. Montažu treba vršiti stručno lice. PAŽNJA !!! Ako uz proizvod su uključeni šrafovi, znači to da su oni namjenjeni samo za zidove napravljene od jedne vrste materijala.

HU –  
A bűtor felfüggesztése illetve falhoz való rögzítése (megakadályozván ezzel eldőlésének lehetőségét) előtt ellenőrizze a fal fajtáját és szilárdságát. Megfelelő, a falhoz illő tipliket és csavarokat használjon. Ha kétsége támadna, konzultáljon szakemberrel. A felszerelést csakis egy hozzáértő szakember végezheti el. FIGYELEM!!! Ha a termékhez tipliket és csavarokat mellékelünk, akkor ezeket csakis tömör és homogén anyagból készült falakhoz szabad használni.

I –  
Prima di appendere i mobili, oppure attaccarli al muro (per proteggerli da ribaltamenti), verifica prima la tipologia e resistenza del muro. Scegli i tasselli e viti più adatti per il tipo di muro. In caso di dubbi contattate uno specialista. Il montaggio deve essere fatto da una persona competente. ATTENZIONE!!! Se viti e tasselli sono inclusi nell'offerta, essi sono utilizzabili solamente per i muri fatti di un certo tipo di materiale.

LV –  
Pirms pakarat, piestiprināt mēbēli pie sienas (lai to aizsargātu pret apgāšanos), pārbaudiet sienas veidu un nestspēju. Izvēlieties sienas veidam atbilstošus dībeļus un skrūves. Šaubu gadījumā sazinieties ar speciālistu. Montāža jāveic kvalificētai personai. UZMANĪBU!!! Ja izstrādājumam ir pievienoti dībeļi ar skrūvēm, tie ir paredzēti tikai un vienīgi sienām, kas izgatavotas no cietiem un viendabīgiem materiāliem.

LT –  
Norint pakabinti baldus (arba pritvirtinti prie sienos), reikia patikrinti sienos kokybę ir stiprumą. Reikia pasirinkti varžtus tinkamus sienos tipui. Kilus klausimams raginame kreiptis į specialistus. Montavimą turi atlikti kompetentingas asmuo. DĖMESIO!!! Varžtai pateikti su baldais yra skirti tik vientisų medžiagų pastatytams sienams.

NL –  
Voordat u het meubel ophangt of bevestigt tegen de muur (om het te beschermen tegen omvallen) dient u het type en de duurzaamheid van deze muur na te kijken. Maak gebruik van pluggen en schroeven die geschikt zijn voor het type muur. Neem in geval van twijfels contact op met een specialist. De assemblage dient te worden uitgevoerd door iemand met kennis van zaken. OPGELET!!! Indien u kunt kiezen uit bijgevoegde pluggen met schroeven, dan zijn deze uitsluitend bestemd voor muren van massieve, homogene materialen.

P –  
Antes de pendurar ou fixar o móvel na parede (a fim de proteger contra a sua queda), verifique com antecedência a sua natureza e resistência. Seleccione buchas e parafusos adequados para o tipo da parede. Em caso de dúvida, consulte um especialista. A montagem deve ser efetuada por uma pessoa competente. ATENÇÃO !!! Se o produto for acompanhado de buchas e parafusos, estes destinam-se só às paredes feitas com materiais sólidos e homogéneos. hh

RO –  
Înainte de suspendarea unei piese de mobilier sau atașarea acesteia la perete (pentru a preveni bascularea), veri-

ficați în prealabil tipul și gradul de rezistență a peretelui. Montați diblurile și șuruburile adecvate pentru tipul de perete. În caz de îndoieli, consultați un specialist. Instalarea trebuie să fie efectuată de către o persoană competentă. ATENȚIE!!! Dacă un produs este livrat împreună cu dibluri cu șuruburi, înseamnă că este proiectat sunt proiectate exclusiv pentru pereți realizați din materiale solide și omogene.

RU –  
Перед подвешиванием мебели или ее креплением к стене (для защиты от падений) проверьте предварительно тип и прочность стены. Подберите соответствующие типу стены дюбели и шурупы. При возникновении сомнений свяжитесь со специалистом. Монтаж должен проводиться компетентным лицом. ВНИМАНИЕ!!! Если к изделию прилагаются распорные дюбеля с шурупами, они предназначены исключительно для стен из литых и однородных материалов.

S –  
Innan möbelen hängs upp eller förankras i väggen (så att den inte välter), kontrollera först hur väggen är uppbyggd och hur mycket den kan belastas. Välj sedan lämplig väggplugg och skruv. Om du är osäker ta kontakt med en specialist. Montage måste utföras av kompetent person. OBS!!! Om produkten levereras med väggplugg och skruv är de avsedda endast till väggar av kompakt homogent material.

SK –  
Pred zavesením nábytku alebo jeho pripevnením na stenu (za účelom zaistenia pred prevrátením) predtým skontrolujte druh a odolnosť steny. Vyberte k druhu steny vhodné hmoždinky a skrutky. V prípade pochybností kontaktujte špecialistu. Montáž musí byť vykonaná kompetentnou osobou. POZOR!!! Pokiaľ sú k výrobku priložené hmoždinky so skrutkami, sú určené len a výhradne do stien zhotovených z masívnych a homogenných materiálov.

SLO –  
Pred montažo pohišta na steno ali pritrditve le-tega k steni (v cilju preprečitve, da se ne prevrne) prej preverite vrsto in močnost stene. Izberite vložke in vijake, ki odgovarjajo vrsti stene. V primeru dvomov se posvetujte z specialistom. Montažo sme opraviti izključno ustrezno kvalificirana oseba. POZOR!!! Če so k izdelku priloženi razporni vložki z vijaki, so le-ti namenjeni samo in izključno za montažo na stene, izdelane iz masivnih in homogenih materialov.

SRB –  
Pre vešanja nameštaja, ili pričvršćivanja ga do zida (radi osiguranja od prevrtanja), treba unapred proveriti vrstu i izdržljivost zida. Treba birati odgovarajuće ekseri e vijke prema određenoj vrsti zida. U slučaju sumnje kontaktirati se sa stručnjakom. Montažu mora izvršiti kompetentno lico. NAPOMENA!!! Ukoliko uz proizvod priloženi su rastezni ekseri sa vijcima, to su oni namenjeni samo i isključivo za zidove izrađene iz čvrstih i jednorodnih materijala.

TR –  
Mobilyayı duvara asmadan veya montaj etmeden önce (devrilmesini önlemek için) duvarın türünü ve dayanıklılığını kontrol edin. Duvara uygun dübelleri ve vidaları seçin. Emin olamamanız durumunda bir uzman ile irtibata geçin. Kurulum yetkili bir kişi tarafından yapılmalıdır. DİKKAT!!! Bir ürün ile birlikte vidalar ve dübeller verilirse, bunlar sadece kati ve homojen malzemelerden yapılmış duvarlara uygundur.

UKR –  
Перед підвішуванням меблів або їх кріпленням до стіни (з метою захисту від падіння) перевірте попередньо тип та міцність стіни. Підберіть відповідні типу стіни дюбелі та шурупи. При наявності сумнівів зв'яжіться зі спеціалістом. Монтаж повинен проводитися компетентною особою. УВАГА!!! Якщо до виробу додаються розпирні дюбелі з шурупами, вони призначаються виключно для стін з литих та однорідних матеріалів.

PL - Mocowanie mebla do ściany / BG - Закрепване на мебелите към стената / CZ - Upevnění nábytku ke zdi / DE - Befestigung der Möbel an der Wand / EN - Fixing the furniture to the wall / ES - Fijando los muebles a la pared / EST - Mööbli kinnitamine seinale / FR - Fixation des meubles au mur / HR - Ugradnja namještaja na zid / HU - A bútorok falhoz rögzítése / I - Fissare i mobili al muro / LT - Baldų tvirtinimas prie sienos / LV - Mēbeļu piestiprināšana pie sienas / NL - Het meubilair aan de muur bevestigen / P - Fixando a mobília na parede / RO - Fixarea mobilierului pe perete / RU - Крепление мебели к стене / S - Fäster möblerna på väggen / SK - Pripevnenie nábytku k stene / SLO - Pritrditev pohištva na steno / SRB - Спајање намештаја на зид / TR - Mobilyayı duvara sabitleme / UKR - Кріплення меблів до стіни /

